



○ FELIZ

PROFILED SHEETING

COLD FORMED SECTIONS





FELIZ

05 **COMPANY**

05 **QUALITY
POLICY**

06 **INTRODUCTION**

07 **PROFILED
SHEETING**

10 **DESIGN
TABLES**

11 **EXAMPLE**

12 **P0-272-30**

14 **P1-272-30**

16 **P2-272-30**

18 **P3-205-60**

20 **P4-76-20**

22 **P5-111-25**

24 **P6-247-45**

26 **C PURLINS**

27 **Z PURLINS**

28 **CONSTRUCTION
DETAILS**

31 **ACCESSORIES**

38 **AVAILABLE
COLORS**

COMPANY

Where we come from, who we are and what we do.

Headquartered in Braga and with more than 6 decades of experience in its field, O FELIZ - Metalomecânica is a company specialized in metallic construction, sheet profiling, cutting and bending of sheets, construction of lighting columns and communication towers, metalworking in stainless steel and laser cutting.

A policy of continuous investment in state of the art equipment and a focus on highly qualified and competent staff allows the company to maintain a production capacity and an immediate response to the market's demands and requests, making it a reference in its fields of action.

With a portfolio of well-known projects and clients, the company has the required knowledge and means to serve in the global market, with solutions starting at the conception and elaboration of the project, all the way to the construction and final assembly.

By focusing on the efficiency of the procedures and keeping a strong market orientation, the company has been able to establish itself in an extremely competitive market, conquering its customer's trust due to the quality of the final product and the ability to follow through within the deadlines.

With a growth strategy aimed at internationalization, O FELIZ - Metalomecânica exports to several countries and has an industrial unit in Angola which has production capacity and the ability to offer solutions for the market's needs and requests.

QUALITY POLICY

Being successful is being happy.

Working in an extremely competitive market, where clients are more and more demanding, the Administration of O FELIZ believes that only with a real involvement, a strong market orientation, the optimization of all resources and a reduction of the activities which do not add value, as well as a strict compliance with the legal and statutory requirements applicable to the product, a sustained growth can be possible.

We are committed to this goal, believing that together we will improve the performance of our organization and we will stand as a reference company.

INTRODUCTION

Profiled sheeting.

The use of profiled sheeting for roofing and cladding façades is a technically and financially competitive solution; by varying the thickness of the sheeting and the geometrical characteristics of the section, we can obtain light components capable of overcoming different spans.

The different profiles are obtained by profiling pre-painted or galvanized, cold-rolled steel coils. The profiled sheeting can be corrugated or trapezoidal, with different profile heights, distances and dimensions; and they can have stiffeners or not.

In order to achieve better thermal and acoustic insulation, we use a layer of insulating material between two sheets of lining.

Zinched screws, self-tapping stainless steel screws or self-drilling screws are used for fixing to the secondary structure.

Using the same type of sheeting, we also manufacture all the accessories required for a perfect waterproofing, such as: casings, trims, ridges, drips, etc.

Next, we briefly outline the main analysis and design assumptions that were considered when creating the design tables for lining sheeting produced by O FELIZ - Metalomecânica S.A.. This study was developed in partnership with the University of Minho, under the coordination of Professor Isabel Valente.

CE MARKING

The Construction Products Directive 89/106/EEC states that the use of self-supporting sheet for roofing, external cladding and internal lining must comply with CE Marking specifications.

Portuguese standard NP EN 14782 defines the criteria for traceability, mechanical resistance, production quality and reaction to fire. All profiles sold by O FELIZ bear the CE Marking label in accordance with the legal and quality standards defined in the norm standard.

For further information on this topic please contact our Technical Department via email to dt@ofeliz.pt.



Universidade do Minho

PROFILED SHEETING

Characteristics of the cladding profiled sheeting manufactured by O FELIZ.

MATERIALS AND COATINGS USED

The cladding sheeting is produced from hot-dip galvanized and pre-painted coils, class S280GD and S320GD, in accordance with the information listed in Tables 1 and 2:

Table 1 – Characteristics of the material

CHARACTERISTICS OF THE MATERIAL		STANDARD
Coating	Hot-dip Galvanized	EN 10346
	Hot-dip Galvanized/Pre-painted	EN 10169

Note :

Continuously hot-dip coated steel flat products - Standard EN 10346:2009 (metallic coatings type Z, ZF, Z, ZA, AS)
Continuously organic coated (coil coated) steel flat products - Standard EN10169:2010

Table 2 – Steel properties

	S280GD	S320GD
Yield Strength, f_{yb}	$f_{yb} \geq 280 \text{ N/mm}^2$	$f_{yb} \geq 320 \text{ N/mm}^2$
Ultimate Tensile Strength, f_u	$f_u \geq 360 \text{ N/mm}^2$	$f_u \geq 390 \text{ N/mm}^2$

GEOMETRIC CHARACTERISTICS

All profiled sheeting manufactured by O FELIZ has a trapezoidal profile, except for one type which has a corrugated profile.

In all the sheet typologies, the following thicknesses are considered: 0,5 mm, 0,6 mm, 0,7 mm and 0,75 mm; except for the support sheet recommended for deck coverings, which comes in 0,7 mm, 0,8 mm, 1,0 mm and 1,2 mm.

In the cold formed sections with trapezoidal geometry, the flat areas intersect through rounded edges.

The radius of curvature for these rounded edges is specified in the design tables for each lining sheet.

The radius of curvature for these edges guarantees a good execution during the manufacturing procedure and it respects the limits imposed by the standard EN1993-1-3.

PROFILED SHEETS

Assumptions and explanations about the use of the tables.

GENERAL ASSUMPTIONS

Standard: The current European Standards is used to analyze the resistance and deformation of the cladding profiled sheeting. The design has in consideration the provisions set by the standards NP EN1993-1-1, EN1993-1-3 and EN1993-1-5.

Structural Scheme: When creating the tables, the following structural scheme situations were considered: panel with simple support (2 supports), two continuous panels with equal spans (3 supports) and three continuous panels with equal spans (4 supports).

Ultimate Limit States: The cladding sheeting is verified in resistance ultimate limit state.

Verifying the resistance ultimate limit state includes the quantification of: resistance to symmetrical bending, resistance to shear stress, resistance to localized force and interaction between localized force and bending moment when these two effects occur simultaneously in the same cross section.

In the case of a panel with simple support, it is considered that the resistant capacity of the sheet can be conditioned by maximum positive bending moment, maximum shear stress in the support or use of concentrated load in the support.

In the case of a continuous panel, it is considered that the resistant capacity of the sheet can be conditioned by maximum positive bending moment in the span, maximum negative bending moment in the support, maximum shear stress in the support, use of concentrated load in the supports or interaction between concentrated load in the middle support and negative bending moment.

Starting from an elastic distribution of the tensions in the cross section, it is considered that in the most strained fiber, the maximum stress installed is equal to the yield stress of the material used. The stress installed in the most strained fiber can come from compression or traction, depending on the geometry of the sheet being analyzed.

In some of the analyzed typologies of sheeting there is a considerable spacing between the cores of the trapezoidal section, resulting in shear lag effects in the distribution of tensions across the tractioned flanges and the compressed flanges. Therefore, the existence of ribs is accounted for in the quantification of the resistant capacity of the section.

Being that the sheeting used is very thin, the chance of local instability phenomenon in the compressed areas of the section needs to be considered.

Local instability results in considering a reduction of the section in the compressed areas of the cross section.

The reduction of the section corresponds to considering areas of the section which are efficient and other areas which are not.

PROFILED SHEETS

Assumptions and explanations about the use of the tables.

The non effective areas of the section can be located in the compressed flanges or in the compressed areas of the cores.

The areas with rounded edges are not accounted for in the calculation of the efficient widths.
The areas with rounded edges are accounted for in the calculation of the cross section's resistant capacity.

In some of the analyzed sheet typologies, there are rigidity ribs in the flanges of the trapezoidal sheet; these ribs correspond to a folding of the sheet.

The existence of rigidity ribs contributes to an increase of efficiency of the compressed flanges. Therefore, the existence of ribs is accounted for in the quantification of the resistant capacity of the section.

Serviceability Limit States: The sheeting is also verified in serviceability limit state – deformation.

In the case of a panel with simple support and a continuous panel, it is considered that the maximum applied load is also limited by the maximum vertical deformation at the panel's midspan.

In general, the limit value for maximum deformation is considered to be equal to $L/200$ for descending loadings and $L/150$ for ascending loadings, where L is the considered sheet's span.

A deformation limit of $L/150$ for ascending loadings is considered, because it is admitted that this deformation is a result of the wind's action.

In some cases, it is considered that the limit value of maximum deformation is equal to $L/200$ both for descending and ascending loadings, since the sheet can also be placed in inverted position.

Types of application for the profiled lining sheets.

PROFILE	TYPE OF APPLICATION		
	ROOF	FAÇADE	SUPPORT
P0-272-30	X	X	X
P1-272-30	X	X	X
P2-272-30	X	X	X
P3-205-60	*	**	X
P4-76-20	*	X	-
P5-111-25	*	X	-
P6-247-45	X	X	X

* For application in coverings please contact our Technical services

** For application in façades please contact our Technical services

DIRECT DESIGN TABLES

Assumptions and explanations about the use of the tables.

EXPLANATORY NOTE ABOUT THE USE OF DIRECT CALCULATION TABLES

The tables are organized in order to provide the maximum load values to apply to the cladding profiled sheeting, for spans of various sizes.

The considered spans have sequential intervals of 10 cm.

It is considered that the spans presented in the tables represent the most appropriate range for its use. Before considering other spans, please contact O FELIZ - Metalomecânica S.A.'s Technical Department.

All the presented tables have in common: the thickness of the sheet, the sheet's class of resistance and the distribution of the supports (sheet with simple support or continuous in two or three spans).

The values listed on the table represent the sum of the characteristic value of the acting loads (overloads, remaining permanent loads, wind, etc) that the cladding profiled sheeting can take, on top of their own weight.

When verifying in Ultimate Limit State, we add $\gamma_g = 1,35$ to the weight of the sheet and $\gamma_q = 1,50$ to the remaining loads (overloads, remaining permanent loads, wind, etc). The load values presented in the tables represent variable loadings, which can be ascending or descending (overloads, remaining permanent loads, wind, etc), as indicated in the tables.

When verifying the deformations in the definite state (serviceability limit states) we used the characteristic combination of actions (in accordance with the standard NP EN 1990:2009).

These loads should not include the weight of the sheet since this was already accounted for.

Other permanent loads should be included in the load value presented in the tables.

The loads listed in the tables are calculated considering a maximum load value that can be applied to the lining sheet; this maximum value is calculated as the minimum load value resulting from the several limit states considered.

All the tables quantify the most relevant characteristics for each sheet, including: Nominal Thickness, Calculation Thickness, Density, Positive Resistant Bending Moment, Negative Resistant Bending Moment, Inertia Moment, Core Resistance to Localized Forces and Resistance to Cut.

The tabled values for Positive Resistant Bending Moment, Negative Resistant Bending Moment, Inertia Moment, Core Resistance to Localized Forces and Resistance to Cut have not taken into account the shear lag effects, since this effect depends on the span. However, these effects are considered in the calculation procedure that led to the creation of the design tables presented here.

EXAMPLE

Using direct design tables.

Design of a roof sheeting covering for the following characteristics:

Structural scheme for continuous panel with 2 supports:

Distance between supports: $L = 2,00$ m

Loads on the profiled roof sheeting (characteristic values):

Sheeting weight

Remaining dead loads: $0,20$ kN/m²

Imposed Loads : $0,30$ kN/m²

Wind load: $0,90$ kN/m²

The request for the design of the sheeting, measured according to the previously described, is:

For descending loads (D):

$$P_{Ed(D)} = 0,20 + 0,30 = 0,50 \text{ kN/m}^2$$

For ascending loads (A):

$$P_{Ed(A)} = -0,90 = -0,90 \text{ kN/m}^2$$

 3 SUPPORTS		SPAN [m]															
Thickness [mm]		1,00	1,10	1,20	1,30	1,40	1,50	1,60	1,70	1,80	1,90	2,00	2,10	2,20	2,30	2,40	2,50
0,50	(D)	1,94	1,69	1,48	1,30	1,16	1,05	0,94	0,85	0,77	0,70	0,65	0,59	0,54	0,50	0,46	0,43
	(A)	2,80	2,32	1,95	1,67	1,44	1,26	1,11	0,99	0,88	0,80	0,72	0,66	0,60	0,55	0,51	0,47
0,60	(D)	2,69	2,33	2,01	1,76	1,55	1,38	1,24	1,11	1,01	0,92	0,84	0,77	0,71	0,65	0,60	0,56
	(A)	4,04	3,34	2,81	2,40	2,08	1,81	1,60	1,42	1,27	1,14	1,03	0,94	0,86	0,79	0,73	0,67
0,70	(D)	3,37	2,90	2,51	2,22	1,96	1,72	1,55	1,40	1,26	1,14	1,05	0,96	0,88	0,81	0,75	0,69
	(A)	5,18	4,29	3,62	3,09	2,67	2,33	2,06	1,83	1,63	1,47	1,33	1,21	1,11	1,02	0,94	0,87

By analysing the design tables we get the **P1-272-30** profile sheeting in the **S280GD** class resistance with a 0,6 mm thickness, and the following values:

Admissible values for descending loads:

$$P_{Ed(D)} = 0,50 \text{ kN/m}^2 \leq P_{Rd(D)} = 0,84 \text{ kN/m}^2 \Rightarrow \text{OK (stability verified)}$$

Admissible values for ascending loads:

$$P_{Ed(A)} = -0,90 \text{ kN/m}^2 \leq P_{Rd(A)} = 1,03 \text{ kN/m}^2 \Rightarrow \text{OK (stability verified)}$$

With this verification, we guarantee that the sheeting will have a maximum deflection equal to $L/200$, i.e., $2000/200 = 10$ mm for ascending loads and $L/150$, i.e., $2000/150 = 13,4$ mm for descending loads.

We can also conclude that the design of the sheeting is conditioned by the U.L.S. sheeting resistance and not by the deformation, which is identified on the direct design table in light grey colour.

Frequently, the direct design tables will present more than one type of sheeting profile. It is up to the designer to select between all possible solutions.

SIDE 1 - ROOF

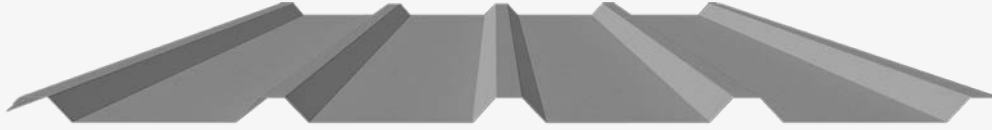

SIDE 2 - FACADE

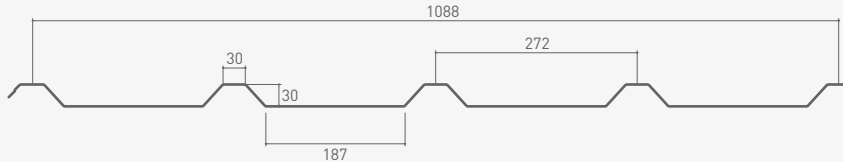

Nominal Thickness [mm]	Design Thickness [mm]	Weight		Superior Flange in Compression		Inferior Flange in Compression		Web Crushing Resistance [kN/m]	Shear Resistance [kN/m]
		kg/m ²	kg/ml	Resistance Moment [kN.m/m]	Inertia Moment [cm ⁴ /m]	Resistance Moment [kN.m/m]	Inertia Moment [cm ⁴ /m]		
0,50	0,46	4,51	4,14	0,52	5,11	0,53	3,24	6,75	15,22
0,60	0,56	5,41	4,97	0,75	6,89	0,71	4,18	9,67	22,56
0,70	0,66	6,31	5,80	0,97	8,54	0,87	5,19	13,04	28,89
0,75	0,71	6,76	6,21	1,07	9,41	0,95	5,71	14,88	31,08

Radius = 4 mm

D descending loads

 SLS - limit deflection:
 L/200 descending loads

A ascending loads

 SLS - limit deflection:
 L/150 ascending loads

Note: All the values for resistant moment and inertia moment presented in this table were calculated without considering shear lag effects.

DIRECT DESIGN TABLES

Admissible load values (with no increases) in kN/m².

loads conditioned by ULS

loads conditioned by SLS

2 SUPPORTS		SPAN [m]															
Thickness [mm]		1,00	1,10	1,20	1,30	1,40	1,50	1,60	1,70	1,80	1,90	2,00	2,10	2,20	2,30	2,40	2,50
0,50	(D)	2,73	2,25	1,88	1,60	1,37	1,17	0,96	0,79	0,66	0,55	0,47	0,40	0,34	0,29	0,25	0,22
	(A)	2,83	2,34	1,98	1,58	1,27	1,03	0,85	0,71	0,60	0,51	0,44	0,38	0,33	0,29	0,25	0,22
0,60	(D)	3,95	3,25	2,73	2,32	1,96	1,58	1,30	1,07	0,90	0,75	0,64	0,55	0,47	0,40	0,35	0,30
	(A)	3,79	3,14	2,60	2,04	1,64	1,33	1,10	0,91	0,77	0,65	0,56	0,49	0,42	0,37	0,33	0,29
0,70	(D)	5,09	4,20	3,52	2,99	2,43	1,97	1,61	1,33	1,11	0,94	0,80	0,68	0,58	0,50	0,43	0,38
	(A)	4,68	3,88	3,22	2,53	2,03	1,65	1,36	1,13	0,95	0,81	0,70	0,60	0,52	0,46	0,40	0,36
0,75	(D)	5,61	4,63	3,88	3,30	2,68	2,17	1,78	1,47	1,23	1,04	0,88	0,75	0,64	0,56	0,48	0,42
	(A)	5,09	4,21	3,54	2,78	2,23	1,81	1,50	1,25	1,05	0,89	0,77	0,66	0,58	0,50	0,44	0,39

3 SUPPORTS		SPAN [m]															
Thickness [mm]		1,00	1,10	1,20	1,30	1,40	1,50	1,60	1,70	1,80	1,90	2,00	2,10	2,20	2,30	2,40	2,50
0,50	(D)	1,77	1,52	1,32	1,16	1,03	0,92	0,82	0,75	0,67	0,61	0,56	0,52	0,48	0,44	0,41	0,38
	(A)	2,80	2,32	1,95	1,67	1,44	1,26	1,11	0,99	0,88	0,80	0,72	0,66	0,60	0,55	0,51	0,47
0,60	(D)	2,41	2,06	1,80	1,58	1,41	1,25	1,12	1,01	0,91	0,83	0,77	0,70	0,65	0,60	0,55	0,51
	(A)	4,04	3,34	2,81	2,40	2,08	1,81	1,60	1,42	1,27	1,14	1,03	0,94	0,86	0,79	0,73	0,67
0,70	(D)	3,10	2,66	2,32	2,04	1,82	1,61	1,44	1,31	1,19	1,08	0,99	0,91	0,84	0,77	0,72	0,67
	(A)	5,18	4,29	3,62	3,09	2,67	2,33	2,06	1,83	1,63	1,47	1,33	1,21	1,11	1,02	0,94	0,87
0,75	(D)	3,48	2,99	2,60	2,30	2,02	1,81	1,62	1,46	1,34	1,22	1,10	1,02	0,93	0,86	0,79	0,73
	(A)	5,71	4,73	3,98	3,40	2,94	2,57	2,26	2,01	1,80	1,62	1,47	1,33	1,22	1,12	1,03	0,95

4 SUPPORTS		SPAN [m]															
Thickness [mm]		1,00	1,10	1,20	1,30	1,40	1,50	1,60	1,70	1,80	1,90	2,00	2,10	2,20	2,30	2,40	2,50
0,50	(D)	2,13	1,83	1,61	1,42	1,26	1,12	1,01	0,91	0,83	0,76	0,69	0,64	0,59	0,54	0,50	0,46
	(A)	3,49	2,89	2,43	2,08	1,79	1,57	1,38	1,23	1,10	0,98	0,83	0,72	0,63	0,55	0,48	0,43
0,60	(D)	2,90	2,49	2,17	1,91	1,70	1,53	1,37	1,25	1,13	1,03	0,94	0,86	0,80	0,74	0,68	0,63
	(A)	5,00	4,17	3,51	2,99	2,58	2,26	1,99	1,75	1,48	1,26	1,08	0,93	0,81	0,71	0,62	0,55
0,70	(D)	3,74	3,22	2,81	2,48	2,21	1,98	1,77	1,60	1,47	1,34	1,22	1,12	1,04	0,96	0,89	0,78
	(A)	6,26	5,27	4,50	3,85	3,33	2,91	2,56	2,17	1,83	1,55	1,33	1,15	1,00	0,88	0,77	0,68
0,75	(D)	4,19	3,61	3,15	2,78	2,48	2,20	2,00	1,80	1,63	1,49	1,38	1,26	1,15	1,06	0,99	0,86
	(A)	6,93	5,84	4,97	4,24	3,67	3,20	2,82	2,39	2,01	1,71	1,47	1,27	1,10	0,97	0,85	0,75

SIDE 1 - ROOF

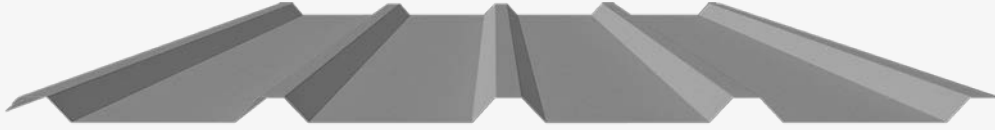

SIDE 2 - FACADE

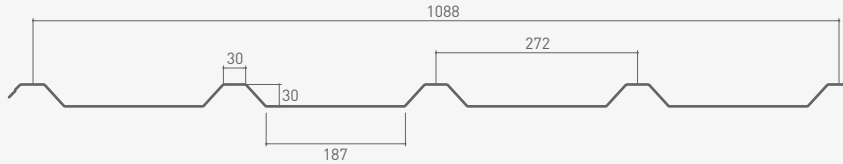

Nominal Thickness [mm]	Design Thickness [mm]	Weight		Superior Flange in Compression		Inferior Flange in Compression		Web Crushing Resistance [kN/m]	Shear Resistance [kN/m]
		kg/m ²	kg/ml	Resistance Moment [kN.m/m]	Inertia Moment [cm ⁴ /m]	Resistance Moment [kN.m/m]	Inertia Moment [cm ⁴ /m]		
0,50	0,46	4,51	4,14	0,56	4,88	0,58	3,18	7,21	16,27
0,60	0,56	5,41	4,97	0,81	6,75	0,78	4,10	10,34	24,11
0,70	0,66	6,31	5,80	1,08	8,37	0,99	5,08	13,94	33,02
0,75	0,71	6,76	6,21	1,19	9,21	1,07	5,59	15,91	35,52

Radius = 4mm



SLS - limit deflection: L/200 descending loads



SLS - limit deflection: L/150 ascending loads

Note: All the values for resistant moment and inertia moment presented in this table were calculated without considering shear lag effects.

DIRECT DESIGN TABLES

Admissible load values (with no increases) in kN/m².

loads conditioned by ULS

loads conditioned by SLS

2 SUPPORTS		SPAN [m]															
Thickness [mm]		1,00	1,10	1,20	1,30	1,40	1,50	1,60	1,70	1,80	1,90	2,00	2,10	2,20	2,30	2,40	2,50
0,50	(D)	2,94	2,42	2,03	1,72	1,38	1,12	0,91	0,75	0,63	0,53	0,45	0,38	0,32	0,28	0,24	0,21
	(A)	3,13	2,56	1,97	1,55	1,24	1,01	0,83	0,69	0,59	0,50	0,43	0,37	0,32	0,28	0,25	0,22
0,60	(D)	4,26	3,51	2,94	2,41	1,92	1,55	1,27	1,05	0,88	0,74	0,63	0,53	0,46	0,39	0,34	0,29
	(A)	4,19	3,30	2,54	2,00	1,60	1,30	1,07	0,90	0,75	0,64	0,55	0,48	0,41	0,36	0,32	0,28
0,70	(D)	5,70	4,70	3,80	2,98	2,38	1,92	1,58	1,30	1,09	0,92	0,78	0,66	0,57	0,49	0,42	0,37
	(A)	5,30	4,09	3,15	2,48	1,99	1,61	1,33	1,11	0,94	0,80	0,68	0,59	0,51	0,45	0,40	0,35
0,75	(D)	6,28	5,18	4,19	3,28	2,62	2,12	1,74	1,44	1,20	1,01	0,86	0,73	0,63	0,54	0,47	0,41
	(A)	5,76	4,50	3,47	2,73	2,18	1,78	1,46	1,22	1,03	0,87	0,75	0,65	0,56	0,49	0,43	0,38

3 SUPPORTS		SPAN [m]															
Thickness [mm]		1,00	1,10	1,20	1,30	1,40	1,50	1,60	1,70	1,80	1,90	2,00	2,10	2,20	2,30	2,40	2,50
0,50	(D)	1,93	1,67	1,46	1,28	1,14	1,02	0,91	0,83	0,75	0,68	0,63	0,57	0,53	0,49	0,45	0,42
	(A)	3,02	2,50	2,10	1,80	1,55	1,36	1,20	1,06	0,95	0,86	0,78	0,71	0,65	0,59	0,55	0,51
0,60	(D)	2,62	2,28	1,98	1,74	1,55	1,37	1,24	1,12	1,01	0,93	0,85	0,78	0,72	0,66	0,61	0,57
	(A)	4,35	3,60	3,03	2,59	2,24	1,95	1,72	1,53	1,37	1,23	1,11	1,01	0,93	0,85	0,78	0,69
0,70	(D)	3,41	2,93	2,55	2,25	2,00	1,78	1,61	1,45	1,31	1,19	1,09	1,00	0,92	0,85	0,79	0,74
	(A)	5,79	4,80	4,04	3,45	2,98	2,60	2,29	2,04	1,82	1,64	1,48	1,35	1,23	1,09	0,96	0,85
0,75	(D)	3,78	3,29	2,87	2,53	2,22	2,00	1,79	1,63	1,47	1,34	1,23	1,13	1,04	0,96	0,89	0,83
	(A)	6,38	5,28	4,45	3,80	3,28	2,87	2,53	2,24	2,01	1,81	1,63	1,49	1,36	1,20	1,06	0,94

4 SUPPORTS		SPAN [m]															
Thickness [mm]		1,00	1,10	1,20	1,30	1,40	1,50	1,60	1,70	1,80	1,90	2,00	2,10	2,20	2,30	2,40	2,50
0,50	(D)	2,35	2,02	1,76	1,55	1,38	1,24	1,12	1,01	0,92	0,84	0,77	0,70	0,65	0,58	0,50	0,44
	(A)	3,76	3,11	2,62	2,24	1,93	1,69	1,49	1,32	1,12	0,95	0,82	0,71	0,62	0,54	0,47	0,42
0,60	(D)	3,15	2,75	2,39	2,11	1,88	1,69	1,51	1,37	1,24	1,13	1,04	0,95	0,88	0,80	0,70	0,62
	(A)	5,43	4,49	3,78	3,22	2,79	2,43	2,06	1,72	1,45	1,23	1,06	0,91	0,79	0,69	0,61	0,54
0,70	(D)	4,11	3,54	3,09	2,73	2,43	2,18	1,95	1,76	1,61	1,47	1,35	1,24	1,14	1,00	0,87	0,77
	(A)	6,97	5,86	5,00	4,30	3,72	3,09	2,55	2,12	1,79	1,52	1,31	1,13	0,98	0,86	0,76	0,67
0,75	(D)	4,61	3,97	3,47	3,06	2,73	2,42	2,20	1,98	1,80	1,65	1,52	1,39	1,27	1,10	0,96	0,84
	(A)	7,71	6,49	5,54	4,74	4,09	3,40	2,80	2,34	1,97	1,68	1,44	1,24	1,08	0,95	0,83	0,74

SIDE 1 - ROOF

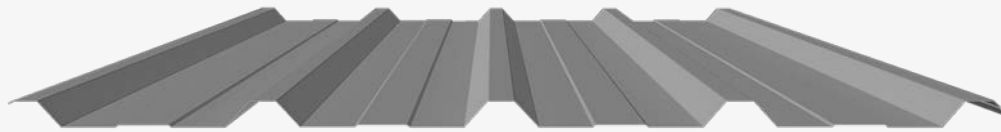

SIDE 2 - FACADE

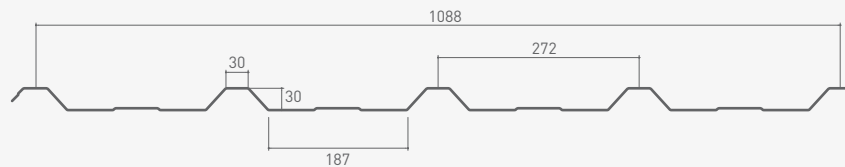

Nominal Thickness [mm]	Design Thickness [mm]	Weight		Superior Flange in Compression		Inferior Flange in Compression		Web Crushing Resistance [kN/m]	Shear Resistance [kN/m]
		kg/m ²	kg/ml	Resistance Moment [kN.m/m]	Inertia Moment [cm ⁴ /m]	Resistance Moment [kN.m/m]	Inertia Moment [cm ⁴ /m]		
0,50	0,46	4,51	4,14	0,52	5,11	0,60	4,33	6,75	15,22
0,60	0,56	5,41	4,97	0,75	6,89	0,75	5,57	9,67	22,56
0,70	0,66	6,31	5,80	0,97	8,54	0,91	6,86	13,04	28,89
0,75	0,71	6,76	6,21	1,07	9,41	0,98	7,51	14,88	31,08

Radius = 4mm

D descending loads

 SLS - limit deflection: L/200 descending loads

A ascending loads

 SLS - limit deflection: L/150 ascending loads

Note: All the values for resistant moment and inertia moment presented in this table were calculated without considering shear lag effects.

DIRECT DESIGN TABLES

Admissible load values (with no increases) in kN/m².

loads conditioned by ULS

loads conditioned by SLS

2 SUPPORTS		SPAN [m]															
Thickness [mm]		1,00	1,10	1,20	1,30	1,40	1,50	1,60	1,70	1,80	1,90	2,00	2,10	2,20	2,30	2,40	2,50
0,50	(D)	2,73	2,25	1,88	1,60	1,37	1,17	0,96	0,79	0,66	0,55	0,47	0,40	0,34	0,29	0,25	0,22
	(A)	3,25	2,69	2,26	1,93	1,67	1,38	1,14	0,95	0,80	0,68	0,58	0,50	0,44	0,38	0,34	0,30
0,60	(D)	3,95	3,25	2,73	2,32	1,96	1,58	1,30	1,07	0,90	0,75	0,64	0,55	0,47	0,40	0,35	0,30
	(A)	4,05	3,35	2,82	2,41	2,08	1,77	1,46	1,22	1,03	0,87	0,75	0,65	0,56	0,49	0,43	0,38
0,70	(D)	5,09	4,20	3,52	2,99	2,43	1,97	1,61	1,33	1,11	0,94	0,80	0,68	0,58	0,50	0,43	0,38
	(A)	4,86	4,03	3,39	2,90	2,50	2,18	1,80	1,50	1,26	1,07	0,92	0,80	0,69	0,61	0,53	0,47
0,75	(D)	5,61	4,63	3,88	3,30	2,68	2,17	1,78	1,47	1,23	1,04	0,88	0,75	0,64	0,56	0,48	0,42
	(A)	5,27	4,37	3,68	3,14	2,71	2,37	1,97	1,64	1,38	1,18	1,01	0,87	0,76	0,66	0,58	0,52

3 SUPPORTS		SPAN [m]															
Thickness [mm]		1,00	1,10	1,20	1,30	1,40	1,50	1,60	1,70	1,80	1,90	2,00	2,10	2,20	2,30	2,40	2,50
0,50	(D)	1,94	1,69	1,48	1,30	1,16	1,05	0,94	0,85	0,77	0,70	0,65	0,59	0,54	0,50	0,46	0,43
	(A)	2,80	2,32	1,95	1,67	1,44	1,26	1,11	0,99	0,88	0,80	0,72	0,66	0,60	0,55	0,51	0,47
0,60	(D)	2,69	2,33	2,01	1,76	1,55	1,38	1,24	1,11	1,01	0,92	0,84	0,77	0,71	0,65	0,60	0,56
	(A)	4,04	3,34	2,81	2,40	2,08	1,81	1,60	1,42	1,27	1,14	1,03	0,94	0,86	0,79	0,73	0,67
0,70	(D)	3,37	2,90	2,51	2,22	1,96	1,72	1,55	1,40	1,26	1,14	1,05	0,96	0,88	0,81	0,75	0,69
	(A)	5,18	4,29	3,62	3,09	2,67	2,33	2,06	1,83	1,63	1,47	1,33	1,21	1,11	1,02	0,94	0,87
0,75	(D)	3,75	3,23	2,79	2,43	2,15	1,91	1,72	1,53	1,38	1,26	1,15	1,05	0,96	0,88	0,82	0,76
	(A)	5,71	4,73	3,98	3,40	2,94	2,57	2,26	2,01	1,80	1,62	1,47	1,33	1,22	1,12	1,03	0,96

4 SUPPORTS		SPAN [m]															
Thickness [mm]		1,00	1,10	1,20	1,30	1,40	1,50	1,60	1,70	1,80	1,90	2,00	2,10	2,20	2,30	2,40	2,50
0,50	(D)	2,36	2,03	1,78	1,57	1,41	1,27	1,15	1,04	0,94	0,87	0,79	0,72	0,67	0,61	0,53	0,46
	(A)	3,49	2,89	2,43	2,08	1,79	1,57	1,38	1,23	1,10	0,99	0,89	0,81	0,74	0,68	0,63	0,57
0,60	(D)	3,23	2,80	2,42	2,12	1,90	1,68	1,51	1,37	1,23	1,13	1,03	0,94	0,88	0,81	0,72	0,63
	(A)	5,04	4,17	3,51	2,99	2,58	2,26	1,99	1,76	1,58	1,42	1,28	1,17	1,07	0,95	0,83	0,74
0,70	(D)	4,11	3,50	3,06	2,68	2,37	2,11	1,90	1,70	1,55	1,41	1,28	1,17	1,09	1,00	0,89	0,78
	(A)	6,47	5,36	4,51	3,85	3,33	2,91	2,56	2,27	2,03	1,83	1,65	1,50	1,33	1,16	1,02	0,91
0,75	(D)	4,52	3,90	3,37	2,94	2,60	2,32	2,09	1,89	1,70	1,54	1,42	1,30	1,19	1,10	0,99	0,86
	(A)	7,12	5,90	4,97	4,24	3,67	3,20	2,82	2,50	2,24	2,01	1,82	1,66	1,46	1,28	1,12	0,99

SIDE 1 - ROOF



SIDE 2 - FACADE

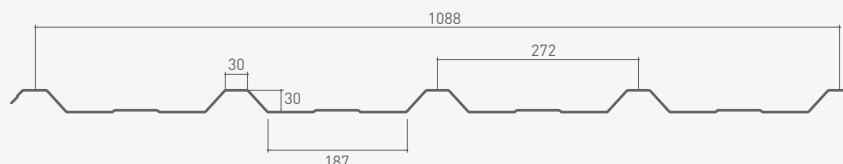

Nominal Thickness [mm]	Design Thickness [mm]	Weight		Superior Flange in Compression		Inferior Flange in Compression		Web Crushing Resistance [kN/m]	Shear Resistance [kN/m]
		kg/m ²	kg/ml	Resistance Moment [kN.m/m]	Inertia Moment [cm ⁴ /m]	Resistance Moment [kN.m/m]	Inertia Moment [cm ⁴ /m]		
0,50	0,46	4,51	4,14	0,56	4,88	0,68	4,25	7,21	16,27
0,60	0,56	5,41	4,97	0,81	6,75	0,85	5,47	10,34	24,11
0,70	0,66	6,31	5,80	1,08	8,37	1,03	6,74	13,94	33,02
0,75	0,71	6,76	6,21	1,19	9,21	1,11	7,39	15,91	35,52

Radius = 4mm

D descending loads
↓ ↓ ↓ ↓

SLS - limit deflection:
L/200 descending loads

A ascending loads
↑ ↑ ↑ ↑

SLS - limit deflection:
L/150 ascending loads

Note: All the values for resistant moment and inertia moment presented in this table were calculated without considering shear lag effects.

DIRECT DESIGN TABLES

Admissible load values (with no increases) in kN/m².

loads conditioned by ULS

loads conditioned by SLS

2 SUPPORTS		SPAN [m]															
Thickness [mm]		1,00	1,10	1,20	1,30	1,40	1,50	1,60	1,70	1,80	1,90	2,00	2,10	2,20	2,30	2,40	2,50
0,50	(D)	2,94	2,42	2,03	1,72	1,38	1,12	0,91	0,75	0,63	0,53	0,45	0,38	0,32	0,28	0,24	0,21
	(A)	3,67	3,04	2,56	2,08	1,66	1,35	1,11	0,93	0,78	0,67	0,57	0,49	0,43	0,38	0,33	0,29
0,60	(D)	4,26	3,51	2,94	2,41	1,92	1,55	1,27	1,05	0,88	0,74	0,63	0,53	0,46	0,39	0,34	0,29
	(A)	4,58	3,79	3,19	2,67	2,14	1,74	1,43	1,20	1,01	0,86	0,74	0,64	0,55	0,48	0,43	0,38
0,70	(D)	5,70	4,70	3,80	2,98	2,38	1,92	1,58	1,30	1,09	0,92	0,78	0,66	0,57	0,49	0,42	0,37
	(A)	5,50	4,56	3,84	3,28	2,64	2,14	1,77	1,47	1,24	1,06	0,91	0,78	0,68	0,60	0,52	0,46
0,75	(D)	6,28	5,18	4,19	3,28	2,62	2,12	1,74	1,44	1,20	1,01	0,86	0,73	0,63	0,54	0,47	0,41
	(A)	5,97	4,94	4,16	3,55	2,89	2,35	1,94	1,62	1,36	1,16	0,99	0,86	0,75	0,65	0,57	0,51

3 SUPPORTS		SPAN [m]															
Thickness [mm]		1,00	1,10	1,20	1,30	1,40	1,50	1,60	1,70	1,80	1,90	2,00	2,10	2,20	2,30	2,40	2,50
0,50	(D)	2,14	1,85	1,64	1,45	1,29	1,15	1,04	0,94	0,86	0,78	0,72	0,67	0,61	0,57	0,52	0,49
	(A)	3,02	2,50	2,10	1,80	1,55	1,36	1,20	1,06	0,95	0,86	0,78	0,71	0,65	0,59	0,55	0,51
0,60	(D)	2,93	2,53	2,21	1,97	1,74	1,56	1,38	1,25	1,13	1,03	0,94	0,86	0,80	0,74	0,68	0,63
	(A)	4,35	3,60	3,03	2,59	2,24	1,95	1,72	1,53	1,37	1,23	1,11	1,01	0,93	0,85	0,78	0,72
0,70	(D)	3,78	3,21	2,81	2,46	2,17	1,94	1,74	1,56	1,42	1,28	1,17	1,07	0,98	0,91	0,84	0,77
	(A)	5,79	4,80	4,04	3,45	2,98	2,60	2,29	2,04	1,82	1,64	1,48	1,35	1,23	1,13	1,04	0,97
0,75	(D)	4,15	3,58	3,09	2,70	2,38	2,13	1,91	1,71	1,56	1,41	1,28	1,17	1,09	1,00	0,93	0,86
	(A)	6,38	5,28	4,45	3,80	3,28	2,87	2,53	2,24	2,01	1,81	1,63	1,49	1,36	1,25	1,15	1,06

4 SUPPORTS		SPAN [m]															
Thickness [mm]		1,00	1,10	1,20	1,30	1,40	1,50	1,60	1,70	1,80	1,90	2,00	2,10	2,20	2,30	2,40	2,50
0,50	(D)	2,57	2,25	1,97	1,74	1,56	1,40	1,26	1,15	1,04	0,95	0,88	0,77	0,66	0,58	0,50	0,44
	(A)	3,76	3,11	2,62	2,24	1,93	1,69	1,49	1,32	1,18	1,06	0,96	0,88	0,80	0,72	0,64	0,56
0,60	(D)	3,52	3,04	2,70	2,38	2,11	1,88	1,70	1,52	1,39	1,26	1,16	1,06	0,93	0,80	0,70	0,62
	(A)	5,43	4,49	3,78	3,22	2,79	2,43	2,14	1,90	1,70	1,53	1,38	1,22	1,06	0,93	0,82	0,72
0,70	(D)	4,54	3,87	3,39	2,97	2,63	2,35	2,11	1,91	1,73	1,56	1,44	1,32	1,15	1,00	0,87	0,77
	(A)	7,23	5,98	5,04	4,30	3,72	3,24	2,86	2,54	2,27	2,03	1,74	1,50	1,31	1,14	1,01	0,89
0,75	(D)	4,99	4,31	3,77	3,30	2,92	2,61	2,32	2,10	1,89	1,74	1,58	1,45	1,27	1,10	0,96	0,84
	(A)	7,96	6,59	5,55	4,74	4,09	3,57	3,15	2,79	2,50	2,22	1,91	1,65	1,43	1,25	1,10	0,98

SIDE 1 - ROOF

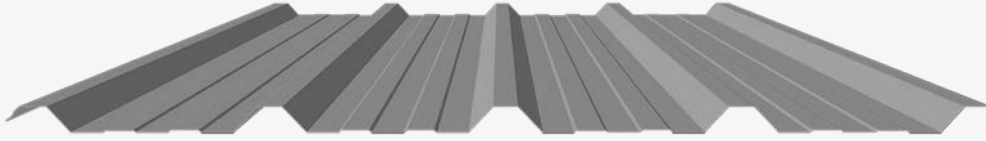

SIDE 2 - FACADE

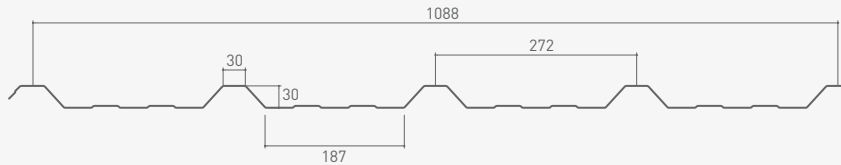

Nominal Thickness [mm]	Design Thickness [mm]	Weight		Superior Flange in Compression		Inferior Flange in Compression		Web Crushing Resistance [kN/m]	Shear Resistance [kN/m]
		kg/m ²	kg/ml	Resistance Moment [kN.m/m]	Inertia Moment [cm ⁴ /m]	Resistance Moment [kN.m/m]	Inertia Moment [cm ⁴ /m]		
0,50	0,46	4,51	4,14	0,52	5,11	0,61	4,91	6,75	15,22
0,60	0,56	5,41	4,97	0,75	6,89	0,75	6,25	9,67	22,56
0,70	0,66	6,31	5,80	0,97	8,54	0,90	7,62	13,04	28,89
0,75	0,71	6,76	6,21	1,07	9,41	0,98	8,31	14,88	31,08

Radius = 4mm

D descending loads

 SLS - limit deflection: L/200 descending loads

A ascending loads

 SLS - limit deflection: L/150 ascending loads

Note: All the values for resistant moment and inertia moment presented in this table were calculated without considering shear lag effects.

DIRECT DESIGN TABLES

Admissible load values (with no increases) in kN/m².

loads conditioned by ULS

loads conditioned by SLS

2 SUPPORTS		SPAN [m]															
Thickness [mm]		1,00	1,10	1,20	1,30	1,40	1,50	1,60	1,70	1,80	1,90	2,00	2,10	2,20	2,30	2,40	2,50
0,50	(D)	2,73	2,25	1,88	1,60	1,37	1,17	0,96	0,79	0,66	0,55	0,47	0,40	0,34	0,29	0,25	0,22
	(A)	3,29	2,72	2,29	1,96	1,69	1,48	1,29	1,07	0,91	0,77	0,66	0,57	0,50	0,43	0,38	0,34
0,60	(D)	3,95	3,25	2,73	2,32	1,96	1,58	1,30	1,07	0,90	0,75	0,64	0,55	0,47	0,40	0,35	0,30
	(A)	4,09	3,39	2,85	2,44	2,10	1,84	1,62	1,37	1,15	0,98	0,84	0,73	0,63	0,55	0,49	0,43
0,70	(D)	5,09	4,20	3,52	2,99	2,43	1,97	1,61	1,33	1,11	0,94	0,80	0,68	0,58	0,50	0,43	0,38
	(A)	4,91	4,06	3,42	2,92	2,52	2,20	1,94	1,67	1,40	1,19	1,02	0,88	0,77	0,67	0,59	0,52
0,75	(D)	5,61	4,63	3,88	3,30	2,68	2,17	1,78	1,47	1,23	1,04	0,88	0,75	0,64	0,56	0,48	0,42
	(A)	5,32	4,40	3,71	3,16	2,74	2,39	2,10	1,82	1,53	1,30	1,12	0,96	0,84	0,73	0,65	0,57

3 SUPPORTS		SPAN [m]															
Thickness [mm]		1,00	1,10	1,20	1,30	1,40	1,50	1,60	1,70	1,80	1,90	2,00	2,10	2,20	2,30	2,40	2,50
0,50	(D)	2,01	1,76	1,53	1,36	1,20	1,07	0,95	0,86	0,79	0,71	0,65	0,60	0,55	0,51	0,47	0,43
	(A)	2,80	2,32	1,95	1,67	1,44	1,26	1,11	0,99	0,88	0,80	0,72	0,66	0,60	0,55	0,51	0,47
0,60	(D)	2,70	2,33	2,04	1,78	1,57	1,40	1,26	1,13	1,03	0,93	0,84	0,78	0,72	0,66	0,61	0,56
	(A)	4,04	3,34	2,81	2,40	2,08	1,81	1,60	1,42	1,27	1,14	1,03	0,94	0,86	0,79	0,73	0,67
0,70	(D)	3,41	2,94	2,54	2,22	1,96	1,74	1,56	1,40	1,27	1,15	1,05	0,97	0,89	0,82	0,75	0,70
	(A)	5,18	4,29	3,62	3,09	2,67	2,33	2,06	1,83	1,63	1,47	1,33	1,21	1,11	1,02	0,94	0,87
0,75	(D)	3,80	3,23	2,82	2,46	2,17	1,93	1,72	1,55	1,40	1,26	1,16	1,06	0,97	0,89	0,83	0,76
	(A)	5,71	4,73	3,98	3,40	2,94	2,57	2,26	2,01	1,80	1,62	1,47	1,33	1,22	1,12	1,03	0,96

4 SUPPORTS		SPAN [m]															
Thickness [mm]		1,00	1,10	1,20	1,30	1,40	1,50	1,60	1,70	1,80	1,90	2,00	2,10	2,20	2,30	2,40	2,50
0,50	(D)	2,41	2,11	1,84	1,64	1,45	1,30	1,17	1,05	0,96	0,87	0,80	0,73	0,67	0,61	0,53	0,46
	(A)	3,49	2,89	2,43	2,08	1,79	1,57	1,38	1,23	1,10	0,99	0,89	0,81	0,74	0,68	0,63	0,58
0,60	(D)	3,23	2,80	2,45	2,15	1,90	1,70	1,53	1,39	1,25	1,15	1,04	0,95	0,88	0,81	0,72	0,63
	(A)	5,04	4,17	3,51	2,99	2,58	2,26	1,99	1,76	1,58	1,42	1,28	1,17	1,07	0,98	0,88	0,77
0,70	(D)	4,10	3,54	3,06	2,71	2,40	2,14	1,90	1,72	1,55	1,42	1,29	1,18	1,09	1,00	0,89	0,78
	(A)	6,47	5,36	4,51	3,85	3,33	2,91	2,56	2,27	2,03	1,83	1,65	1,50	1,37	1,23	1,08	0,95
0,75	(D)	4,57	3,89	3,40	2,98	2,63	2,35	2,11	1,89	1,72	1,56	1,42	1,30	1,20	1,11	0,99	0,86
	(A)	7,12	5,90	4,97	4,24	3,67	3,20	2,82	2,50	2,24	2,01	1,82	1,66	1,51	1,35	1,18	1,03

SIDE 1 - ROOF

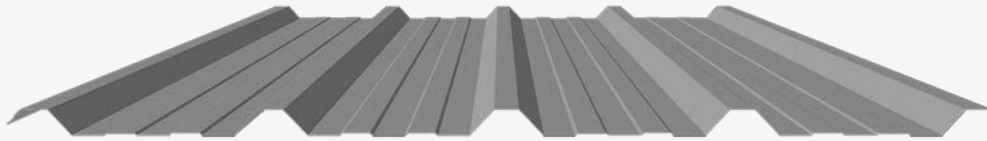

SIDE 2 - FACADE

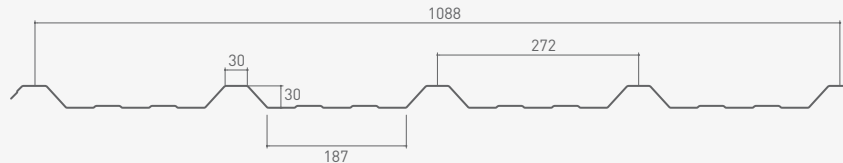

Nominal Thickness [mm]	Design Thickness [mm]	Weight		Superior Flange in Compression		Inferior Flange in Compression		Web Crushing Resistance [kN/m]	Shear Resistance [kN/m]
		kg/m ²	kg/ml	Resistance Moment [kN.m/m]	Inertia Moment [cm ⁴ /m]	Resistance Moment [kN.m/m]	Inertia Moment [cm ⁴ /m]		
0,50	0,46	4,51	4,14	0,56	4,88	0,69	4,83	7,21	16,27
0,60	0,56	5,41	4,97	0,81	6,75	0,86	6,16	10,34	24,11
0,70	0,66	6,31	5,80	1,08	8,37	1,02	7,52	13,94	33,02
0,75	0,71	6,76	6,21	1,19	9,21	1,11	8,21	15,91	35,52

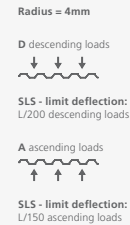

Note: All the values for resistant moment and inertia moment presented in this table were calculated without considering shear lag effects.

DIRECT DESIGN TABLES

Admissible load values (with no increases) in kN/m².

loads conditioned by ULS

loads conditioned by SLS

2 SUPPORTS		SPAN [m]															
Thickness [mm]		1,00	1,10	1,20	1,30	1,40	1,50	1,60	1,70	1,80	1,90	2,00	2,10	2,20	2,30	2,40	2,50
0,50	(D)	2,94	2,42	2,03	1,72	1,38	1,12	0,91	0,75	0,63	0,53	0,45	0,38	0,32	0,28	0,24	0,21
	(A)	3,72	3,08	2,59	2,21	1,89	1,54	1,27	1,06	0,89	0,76	0,65	0,56	0,49	0,43	0,38	0,33
0,60	(D)	4,26	3,51	2,94	2,41	1,92	1,55	1,27	1,05	0,88	0,74	0,63	0,53	0,46	0,39	0,34	0,29
	(A)	4,63	3,83	3,23	2,75	2,38	1,96	1,62	1,35	1,14	0,97	0,83	0,72	0,62	0,54	0,48	0,42
0,70	(D)	5,70	4,70	3,80	2,98	2,38	1,92	1,58	1,30	1,09	0,92	0,78	0,66	0,57	0,49	0,42	0,37
	(A)	5,55	4,60	3,87	3,30	2,86	2,39	1,97	1,64	1,38	1,18	1,01	0,87	0,76	0,66	0,58	0,52
0,75	(D)	6,28	5,18	4,19	3,28	2,62	2,12	1,74	1,44	1,20	1,01	0,86	0,73	0,63	0,54	0,47	0,41
	(A)	6,02	4,98	4,20	3,58	3,10	2,61	2,15	1,79	1,51	1,29	1,10	0,95	0,83	0,73	0,64	0,56

3 SUPPORTS		SPAN [m]															
Thickness [mm]		1,00	1,10	1,20	1,30	1,40	1,50	1,60	1,70	1,80	1,90	2,00	2,10	2,20	2,30	2,40	2,50
0,50	(D)	2,19	1,92	1,67	1,48	1,32	1,19	1,07	0,96	0,87	0,79	0,73	0,67	0,61	0,57	0,53	0,49
	(A)	3,02	2,50	2,10	1,80	1,55	1,36	1,20	1,06	0,95	0,86	0,78	0,71	0,65	0,59	0,55	0,51
0,60	(D)	3,02	2,57	2,25	1,97	1,74	1,56	1,40	1,27	1,14	1,03	0,95	0,87	0,80	0,74	0,68	0,63
	(A)	4,35	3,60	3,03	2,59	2,24	1,95	1,72	1,53	1,37	1,23	1,11	1,01	0,93	0,85	0,78	0,72
0,70	(D)	3,77	3,25	2,81	2,49	2,20	1,96	1,74	1,58	1,42	1,30	1,18	1,08	0,99	0,91	0,84	0,78
	(A)	5,79	4,80	4,04	3,45	2,98	2,60	2,29	2,04	1,82	1,64	1,48	1,35	1,23	1,13	1,04	0,97
0,75	(D)	4,20	3,62	3,12	2,73	2,41	2,15	1,93	1,73	1,57	1,42	1,30	1,18	1,09	1,00	0,93	0,86
	(A)	6,38	5,28	4,45	3,80	3,28	2,87	2,53	2,24	2,01	1,81	1,63	1,49	1,36	1,25	1,15	1,06

4 SUPPORTS		SPAN [m]															
Thickness [mm]		1,00	1,10	1,20	1,30	1,40	1,50	1,60	1,70	1,80	1,90	2,00	2,10	2,20	2,30	2,40	2,50
0,50	(D)	2,66	2,30	2,01	1,78	1,59	1,43	1,29	1,18	1,06	0,97	0,89	0,77	0,66	0,58	0,50	0,44
	(A)	3,76	3,11	2,62	2,24	1,93	1,69	1,49	1,32	1,18	1,06	0,96	0,88	0,80	0,73	0,68	0,60
0,60	(D)	3,62	3,08	2,71	2,38	2,10	1,88	1,70	1,54	1,39	1,27	1,16	1,07	0,93	0,80	0,70	0,62
	(A)	5,43	4,49	3,78	3,22	2,79	2,43	2,14	1,90	1,70	1,53	1,38	1,26	1,14	0,99	0,87	0,76
0,70	(D)	4,53	3,91	3,43	3,00	2,66	2,37	2,14	1,91	1,75	1,58	1,44	1,33	1,15	1,00	0,87	0,77
	(A)	7,23	5,98	5,04	4,30	3,72	3,24	2,86	2,54	2,27	2,04	1,84	1,62	1,40	1,22	1,06	0,93
0,75	(D)	5,05	4,36	3,77	3,30	2,95	2,60	2,34	2,12	1,91	1,75	1,60	1,47	1,27	1,10	0,96	0,84
	(A)	7,96	6,59	5,55	4,74	4,09	3,57	3,15	2,79	2,50	2,25	2,03	1,76	1,53	1,33	1,16	1,02

SIDE 1 - ROOF

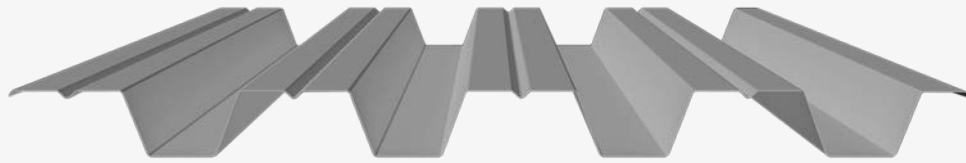

SIDE 2 - FACADE

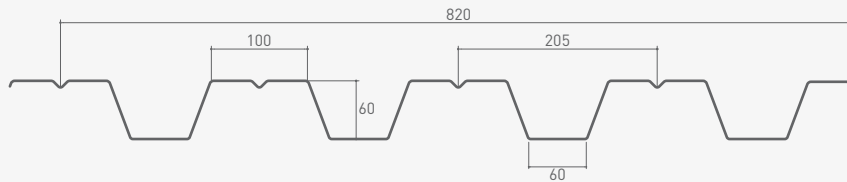

Nominal Thickness [mm]	Design Thickness [mm]	Weight		Superior Flange in Compression		Inferior Flange in Compression		Web Crushing Resistance [kN/m]	Shear Resistance [kN/m]
		kg/m ²	kg/ml	Resistance Moment [kN.m/m]	Inertia Moment [cm ⁴ /m]	Resistance Moment [kN.m/m]	Inertia Moment [cm ⁴ /m]		
0,70	0,66	8,38	10,22	4,28	51,17	2,98	46,78	18,60	41,11
0,80	0,76	9,57	11,67	4,99	60,91	3,90	56,04	24,09	54,51
1,00	0,96	11,97	14,60	6,44	81,26	5,43	75,60	36,88	86,93
1,20	1,16	14,36	17,51	7,90	95,93	7,06	96,31	52,00	105,04

Radius = 4mm

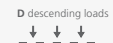

SLS - limit deflection: L/200 descending loads



SLS - limit deflection: L/150 ascending loads

Note: All the values for resistant moment and inertia moment presented in this table were calculated without considering shear lag effects.

DIRECT DESIGN TABLES

Admissible load values (with no increases) in kN/m².

loads conditioned by ULS

loads conditioned by SLS

2 SUPPORTS		SPAN [m]																						
Thickness [mm]		1,80	1,90	2,00	2,10	2,20	2,30	2,40	2,50	2,60	2,70	2,80	2,90	3,00	3,10	3,20	3,30	3,40	3,50	3,60	3,70	3,80	3,90	4,00
0,70	(D)	6,96	5,93	5,08	4,37	3,79	3,31	2,90	2,56	2,27	2,01	1,80	1,61	1,45	1,30	1,18	1,07	0,97	0,88	0,80	0,73	0,67	0,61	0,56
	(A)	4,83	4,33	3,90	3,53	3,21	2,93	2,64	2,33	2,06	1,83	1,64	1,46	1,32	1,18	1,07	0,97	0,88	0,80	0,73	0,66	0,61	0,55	0,51
0,80	(D)	8,13	7,07	6,05	5,21	4,52	3,94	3,46	3,05	2,70	2,40	2,14	1,92	1,73	1,55	1,40	1,27	1,16	1,05	0,96	0,88	0,80	0,73	0,67
	(A)	6,33	5,67	5,11	4,63	4,15	3,62	3,17	2,80	2,48	2,20	1,96	1,76	1,58	1,42	1,29	1,16	1,06	0,96	0,87	0,80	0,73	0,67	0,61
1,00	(D)	10,49	9,41	8,07	6,96	6,04	5,27	4,62	4,08	3,61	3,21	2,87	2,57	2,31	2,08	1,88	1,71	1,55	1,41	1,29	1,18	1,08	0,99	0,91
	(A)	8,82	7,91	7,13	6,45	5,60	4,89	4,29	3,78	3,35	2,98	2,66	2,38	2,14	1,93	1,74	1,58	1,43	1,30	1,19	1,09	0,99	0,91	0,84
1,20	(D)	12,87	11,14	9,53	8,21	7,12	6,22	5,46	4,81	4,26	3,79	3,38	3,03	2,72	2,46	2,22	2,01	1,83	1,66	1,52	1,39	1,27	1,16	1,07
	(A)	11,49	10,30	9,28	8,23	7,14	6,23	5,47	4,83	4,28	3,80	3,40	3,04	2,74	2,47	2,23	2,02	1,84	1,67	1,52	1,39	1,27	1,17	1,07

3 SUPPORTS		SPAN [m]																						
Thickness [mm]		1,80	1,90	2,00	2,10	2,20	2,30	2,40	2,50	2,60	2,70	2,80	2,90	3,00	3,10	3,20	3,30	3,40	3,50	3,60	3,70	3,80	3,90	4,00
0,70	(D)	3,12	2,88	2,65	2,47	2,28	2,14	1,99	1,85	1,73	1,62	1,52	1,43	1,35	1,28	1,21	1,15	1,09	1,04	0,98	0,93	0,89	0,85	0,81
	(A)	3,69	3,45	3,21	3,01	2,78	2,58	2,45	2,29	2,14	2,01	1,90	1,79	1,69	1,61	1,53	1,45	1,38	1,32	1,26	1,21	1,14	1,09	1,05
0,80	(D)	4,06	3,70	3,47	3,24	2,99	2,77	2,61	2,43	2,27	2,13	2,00	1,88	1,78	1,68	1,59	1,51	1,44	1,35	1,29	1,23	1,18	1,11	1,07
	(A)	4,66	4,26	3,94	3,69	3,41	3,21	2,99	2,80	2,62	2,50	2,35	2,22	2,10	1,99	1,88	1,79	1,68	1,61	1,53	1,47	1,40	1,33	1,28
1,00	(D)	5,89	5,44	5,06	4,71	4,34	4,02	3,78	3,53	3,29	3,09	2,90	2,73	2,58	2,44	2,31	2,19	2,06	1,96	1,87	1,78	1,69	1,61	1,55
	(A)	6,52	6,04	5,60	5,15	4,82	4,47	4,16	3,93	3,68	3,45	3,25	3,06	2,89	2,74	2,60	2,47	2,35	2,21	2,11	2,02	1,93	1,83	1,75
1,20	(D)	7,89	7,29	6,87	6,31	5,81	5,45	5,06	4,71	4,40	4,13	3,88	3,65	3,44	3,26	3,08	2,93	2,78	2,62	2,50	2,38	2,25	2,16	2,07
	(A)	8,49	7,85	7,28	6,78	6,26	5,79	5,46	5,09	4,76	4,46	4,19	3,95	3,73	3,53	3,34	3,17	3,02	2,84	2,71	2,59	2,48	2,35	2,25

4 SUPPORTS		SPAN [m]																						
Thickness [mm]		1,80	1,90	2,00	2,10	2,20	2,30	2,40	2,50	2,60	2,70	2,80	2,90	3,00	3,10	3,20	3,30	3,40	3,50	3,60	3,70	3,80	3,90	4,00
0,70	(D)	3,73	3,45	3,18	2,97	2,74	2,58	2,40	2,23	2,09	1,99	1,87	1,76	1,66	1,57	1,47	1,40	1,33	1,27	1,21	1,15	1,09	1,05	1,00
	(A)	4,40	4,08	3,80	3,56	3,34	3,10	2,92	2,73	2,59	2,43	2,29	2,19	2,07	1,96	1,86	1,76	1,68	1,61	1,47	1,35	1,24	1,14	1,05
0,80	(D)	4,86	4,43	4,17	3,89	3,59	3,38	3,14	2,93	2,74	2,57	2,42	2,28	2,16	2,04	1,93	1,84	1,75	1,67	1,59	1,50	1,44	1,38	1,32
	(A)	5,47	5,08	4,74	4,44	4,11	3,81	3,61	3,37	3,16	2,97	2,84	2,68	2,53	2,40	2,28	2,17	2,07	1,93	1,77	1,62	1,49	1,37	1,26
1,00	(D)	7,06	6,53	6,08	5,67	5,23	4,91	4,57	4,26	3,98	3,74	3,51	3,31	3,13	2,96	2,81	2,67	2,54	2,42	2,28	2,18	2,08	2,00	1,85
	(A)	7,78	7,22	6,69	6,16	5,78	5,37	5,07	4,73	4,43	4,16	3,92	3,70	3,50	3,31	3,14	2,99	2,85	2,62	2,40	2,20	2,02	1,86	1,71
1,20	(D)	9,61	8,76	8,26	7,59	7,10	6,57	6,11	5,70	5,40	5,06	4,76	4,48	4,23	4,00	3,75	3,56	3,39	3,23	3,05	2,80	2,57	2,37	2,18
	(A)	10,32	9,41	8,73	8,15	7,52	7,07	6,58	6,14	5,74	5,39	5,07	4,78	4,52	4,28	4,06	3,86	3,66	3,34	3,06	2,81	2,58	2,38	2,19

SIDE 1 - ROOF

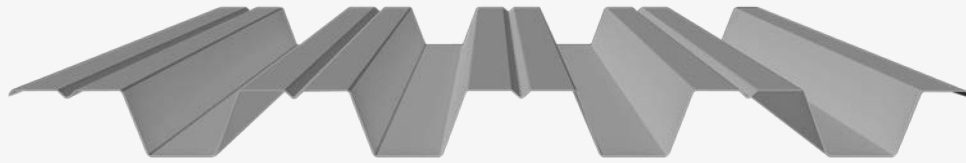

SIDE 2 - FACADE

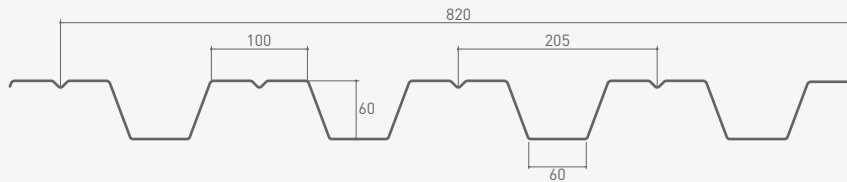

Nominal Thickness [mm]	Design Thickness [mm]	Weight		Superior Flange in Compression		Inferior Flange in Compression		Web Crushing Resistance [kN/m]	Shear Resistance [kN/m]
		kg/m ²	kg/ml	Resistance Moment [kN.m/m]	Inertia Moment [cm ⁴ /m]	Resistance Moment [kN.m/m]	Inertia Moment [cm ⁴ /m]		
0,70	0,66	8,38	10,22	4,83	50,36	3,21	45,08	19,89	43,95
0,80	0,76	9,57	11,67	5,66	59,96	4,20	55,00	25,76	58,28
1,00	0,96	11,97	14,60	7,31	79,98	6,04	74,20	39,43	92,98
1,20	1,16	14,36	17,51	8,97	95,93	7,86	94,54	55,59	120,04

Radius = 4mm



SLS - limit deflection: L/200 descending loads



SLS - limit deflection: L/150 ascending loads

NOTE: All the values for resistant moment and inertia moment presented in this table were calculated without considering shear lag effects.

DIRECT DESIGN TABLES

Admissible load values (with no increases) in kN/m².

loads conditioned by ULS

loads conditioned by SLS

2 SUPPORTS		SPAN [m]																						
Thickness [mm]		1,80	1,90	2,00	2,10	2,20	2,30	2,40	2,50	2,60	2,70	2,80	2,90	3,00	3,10	3,20	3,30	3,40	3,50	3,60	3,70	3,80	3,90	4,00
0,70	(D)	6,88	5,84	4,99	4,30	3,73	3,26	2,86	2,52	2,23	1,98	1,77	1,58	1,42	1,28	1,16	1,05	0,95	0,86	0,79	0,72	0,66	0,60	0,55
	(A)	5,21	4,67	4,20	3,81	3,33	2,90	2,55	2,24	1,99	1,76	1,57	1,41	1,26	1,14	1,03	0,93	0,84	0,77	0,70	0,64	0,58	0,53	0,49
0,80	(D)	8,20	6,96	5,95	5,13	4,45	3,88	3,40	3,00	2,66	2,36	2,11	1,89	1,70	1,53	1,38	1,25	1,14	1,03	0,94	0,86	0,79	0,72	0,66
	(A)	6,82	6,11	5,44	4,69	4,07	3,55	3,11	2,74	2,43	2,16	1,93	1,72	1,55	1,39	1,26	1,14	1,03	0,94	0,86	0,78	0,71	0,65	0,60
1,00	(D)	10,94	9,29	7,94	6,85	5,94	5,18	4,55	4,01	3,55	3,16	2,82	2,53	2,27	2,05	1,85	1,68	1,52	1,39	1,26	1,16	1,06	0,97	0,89
	(A)	9,83	8,59	7,35	6,33	5,49	4,79	4,21	3,71	3,29	2,92	2,61	2,34	2,10	1,89	1,71	1,55	1,40	1,28	1,17	1,06	0,97	0,89	0,82
1,20	(D)	13,12	11,14	9,53	8,21	7,12	6,22	5,46	4,81	4,26	3,79	3,38	3,03	2,72	2,46	2,22	2,01	1,83	1,66	1,52	1,39	1,27	1,16	1,07
	(A)	12,81	10,96	9,37	8,08	7,01	6,12	5,37	4,74	4,20	3,73	3,33	2,98	2,68	2,42	2,19	1,98	1,80	1,64	1,49	1,36	1,25	1,14	1,05

3 SUPPORTS		SPAN [m]																						
Thickness [mm]		1,80	1,90	2,00	2,10	2,20	2,30	2,40	2,50	2,60	2,70	2,80	2,90	3,00	3,10	3,20	3,30	3,40	3,50	3,60	3,70	3,80	3,90	4,00
0,70	(D)	3,36	3,11	2,86	2,66	2,46	2,27	2,14	2,00	1,87	1,75	1,64	1,55	1,46	1,38	1,31	1,24	1,18	1,11	1,06	1,01	0,96	0,91	0,87
	(A)	4,06	3,73	3,50	3,28	3,04	2,87	2,68	2,51	2,35	2,25	2,12	2,00	1,89	1,80	1,71	1,62	1,55	1,46	1,39	1,33	1,28	1,23	1,16
0,80	(D)	4,40	4,07	3,74	3,44	3,22	2,98	2,77	2,62	2,45	2,29	2,16	2,03	1,92	1,81	1,72	1,63	1,53	1,46	1,39	1,33	1,27	1,20	1,15
	(A)	5,11	4,67	4,40	4,06	3,81	3,54	3,30	3,08	2,93	2,76	2,60	2,45	2,32	2,20	2,09	1,99	1,89	1,81	1,70	1,63	1,56	1,50	1,42
1,00	(D)	6,47	5,89	5,56	5,11	4,78	4,43	4,11	3,88	3,63	3,40	3,20	3,01	2,84	2,69	2,55	2,39	2,27	2,17	2,07	1,97	1,87	1,79	1,71
	(A)	7,18	6,66	6,17	5,76	5,32	4,94	4,66	4,35	4,07	3,82	3,60	3,39	3,21	3,04	2,88	2,74	2,61	2,49	2,38	2,24	2,15	2,06	1,95
1,20	(D)	8,68	8,02	7,45	6,94	6,40	6,00	5,58	5,20	4,86	4,55	4,28	4,03	3,80	3,60	3,41	3,23	3,08	2,90	2,76	2,64	2,49	2,39	2,29
	(A)	9,52	8,68	8,05	7,50	6,93	6,51	6,05	5,64	5,28	4,95	4,66	4,39	4,15	3,93	3,72	3,54	3,37	3,21	3,03	2,89	2,77	2,65	2,52

4 SUPPORTS		SPAN [m]																						
Thickness [mm]		1,80	1,90	2,00	2,10	2,20	2,30	2,40	2,50	2,60	2,70	2,80	2,90	3,00	3,10	3,20	3,30	3,40	3,50	3,60	3,70	3,80	3,90	4,00
0,70	(D)	4,02	3,72	3,43	3,20	2,95	2,78	2,58	2,41	2,25	2,12	1,99	1,88	1,77	1,68	1,59	1,51	1,44	1,37	1,31	1,23	1,18	1,13	1,08
	(A)	4,83	4,47	4,23	3,89	3,65	3,44	3,20	3,03	2,83	2,69	2,53	2,39	2,29	2,17	2,05	1,86	1,70	1,55	1,42	1,30	1,19	1,10	1,01
0,80	(D)	5,26	4,87	4,49	4,19	3,87	3,59	3,38	3,16	2,96	2,77	2,61	2,46	2,32	2,20	2,09	1,98	1,89	1,80	1,70	1,62	1,55	1,47	1,36
	(A)	6,10	5,57	5,19	4,86	4,49	4,24	3,95	3,74	3,51	3,29	3,10	2,97	2,81	2,66	2,51	2,28	2,08	1,90	1,73	1,59	1,46	1,34	1,24
1,00	(D)	7,74	7,06	6,67	6,23	5,75	5,33	5,02	4,69	4,39	4,11	3,87	3,65	3,45	3,26	3,10	2,94	2,80	2,64	2,54	2,33	2,14	1,97	1,82
	(A)	8,55	7,94	7,37	6,89	6,38	5,92	5,60	5,23	4,90	4,60	4,34	4,09	3,87	3,67	3,39	3,08	2,81	2,57	2,35	2,15	1,98	1,82	1,68
1,20	(D)	10,40	9,63	9,08	8,35	7,70	7,23	6,73	6,27	5,87	5,51	5,24	4,94	4,67	4,36	4,14	3,93	3,64	3,33	3,05	2,80	2,57	2,37	2,18
	(A)	11,38	10,38	9,63	9,00	8,31	7,82	7,28	6,80	6,36	6,05	5,70	5,37	5,08	4,78	4,33	3,94	3,59	3,28	3,00	2,75	2,53	2,33	2,15

SIDE 1 - FACADE

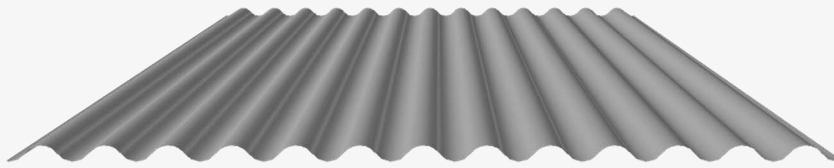

SIDE 2 - ROOF

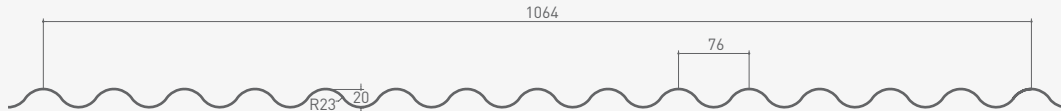

Nominal Thickness [mm]	Design Thickness [mm]	Weight		Resistance Moment [kN.m/m]	Inertia Moment [cm ⁴ /m]	Web Crushing Resistance [kN/m]	Shear Resistance [kN/m]
		kg/m ²	kg/ml				
0,50	0,46	4,61	4,33	0,75	2,66	23,92	38,33
0,60	0,56	5,53	5,20	0,91	3,24	34,29	46,67
0,70	0,66	6,46	6,07	1,06	3,82	46,22	55,00
0,75	0,71	6,92	6,50	1,14	4,11	52,75	59,17

Radius = 4mm

D descending loads



SLS - limit deflection: L/200 descending loads

A ascending loads



SLS - limit deflection: L/150 ascending loads

Note: All the values for resistant moment and inertia moment presented in this table were calculated without considering shear lag effects.

DIRECT DESIGN TABLES

Admissible load values (with no increases) in kN/m².

loads conditioned by ULS

loads conditioned by SLS

2 SUPPORTS		SPAN [m]															
Thickness [mm]		1,00	1,10	1,20	1,30	1,40	1,50	1,60	1,70	1,80	1,90	2,00	2,10	2,20	2,30	2,40	2,50
0,50	(D)	2,10	1,57	1,20	0,93	0,74	0,59	0,48	0,39	0,32	0,27	0,22	-	-	-	-	-
	(A)	2,15	1,61	1,24	0,98	0,78	0,64	0,52	0,44	0,37	0,31	0,27	-	-	-	-	-
0,60	(D)	2,56	1,91	1,46	1,14	0,90	0,72	0,58	0,48	0,39	0,33	0,27	-	-	-	-	-
	(A)	2,62	1,97	1,51	1,19	0,95	0,78	0,64	0,53	0,45	0,38	0,33	-	-	-	-	-
0,70	(D)	3,02	2,25	1,72	1,34	1,06	0,85	0,69	0,56	0,47	0,39	0,32	-	-	-	-	-
	(A)	3,08	2,32	1,78	1,40	1,12	0,91	0,75	0,63	0,53	0,45	0,39	-	-	-	-	-
0,75	(D)	3,25	2,42	1,85	1,44	1,14	0,92	0,74	0,61	0,50	0,42	0,35	-	-	-	-	-
	(A)	3,32	2,49	1,92	1,51	1,21	0,98	0,81	0,68	0,57	0,48	0,41	-	-	-	-	-

3 SUPPORTS		SPAN [m]															
Thickness [mm]		1,00	1,10	1,20	1,30	1,40	1,50	1,60	1,70	1,80	1,90	2,00	2,10	2,20	2,30	2,40	2,50
0,50	(D)	3,75	3,15	2,70	2,32	1,86	1,51	1,23	1,02	0,85	0,72	0,61	0,52	0,45	-	-	-
	(A)	3,77	3,19	2,74	2,36	1,91	1,55	1,28	1,07	0,90	0,76	0,65	0,57	0,49	-	-	-
0,60	(D)	4,68	3,94	3,30	2,81	2,27	1,84	1,50	1,24	1,04	0,88	0,74	0,63	0,54	0,47	-	-
	(A)	4,77	3,99	3,39	2,89	2,33	1,89	1,56	1,30	1,09	0,93	0,80	0,69	0,60	0,52	-	-
0,70	(D)	5,61	4,62	3,87	3,29	2,68	2,17	1,77	1,47	1,23	1,03	0,88	0,75	0,64	0,55	0,48	-
	(A)	5,71	4,72	3,98	3,39	2,74	2,23	1,84	1,53	1,29	1,10	0,94	0,81	0,71	0,62	0,54	-
0,75	(D)	6,02	4,96	4,16	3,53	2,88	2,33	1,91	1,58	1,32	1,11	0,94	0,81	0,69	0,60	0,52	0,45
	(A)	6,13	5,07	4,27	3,64	2,95	2,40	1,98	1,65	1,39	1,18	1,01	0,87	0,76	0,67	0,59	0,52

4 SUPPORTS		SPAN [m]															
Thickness [mm]		1,00	1,10	1,20	1,30	1,40	1,50	1,60	1,70	1,80	1,90	2,00	2,10	2,20	2,30	2,40	2,50
0,50	(D)	4,09	3,06	2,35	1,83	1,46	1,18	0,96	0,80	0,66	0,56	0,47	0,40	0,34	-	-	-
	(A)	4,13	3,10	2,39	1,88	1,51	1,22	1,01	0,84	0,71	0,60	0,52	0,45	0,39	-	-	-
0,60	(D)	4,98	3,73	2,86	2,24	1,78	1,44	1,17	0,97	0,81	0,68	0,57	0,49	0,42	0,36	-	-
	(A)	5,03	3,78	2,91	2,29	1,83	1,49	1,23	1,02	0,86	0,73	0,63	0,54	0,47	0,41	-	-
0,70	(D)	5,87	4,39	3,37	2,64	2,10	1,69	1,38	1,14	0,95	0,80	0,68	0,58	0,49	0,42	0,37	-
	(A)	5,93	4,46	3,43	2,70	2,16	1,76	1,45	1,21	1,02	0,86	0,74	0,64	0,56	0,49	0,43	-
0,75	(D)	6,31	4,73	3,62	2,84	2,26	1,82	1,49	1,23	1,03	0,86	0,73	0,62	0,53	0,46	0,39	0,34
	(A)	6,38	4,79	3,69	2,90	2,33	1,89	1,56	1,30	1,09	0,93	0,80	0,69	0,60	0,52	0,46	0,41

SIDE 1 - FACADE

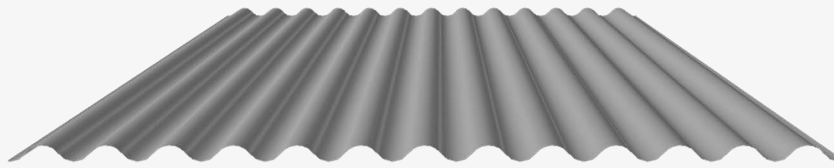

SIDE 2 - ROOF

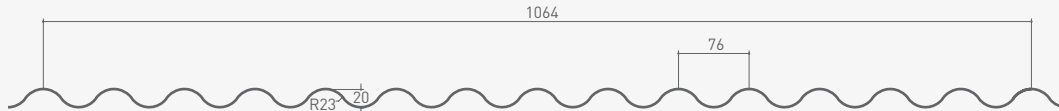

Nominal Thickness [mm]	Design Thickness [mm]	Weight		Resistance Moment [kN.m/m]	Inertia Moment [cm ⁴ /m]	Web Crushing Resistance [kN/m]	Shear Resistance [kN/m]
		kg/m ²	kg/ml				
0,50	0,46	4,61	4,33	0,85	0,85	25,57	43,81
0,60	0,56	5,53	5,20	1,03	1,03	36,65	53,34
0,70	0,66	6,46	6,07	1,21	1,21	49,41	62,86
0,75	0,71	6,92	6,50	1,30	1,30	56,39	67,62

Radius = 4mm

D descending loads



SLS - limit deflection: L/200 descending loads

A ascending loads



SLS - limit deflection: L/150 ascending loads

Note: All the values for resistant moment and inertia moment presented in this table were calculated without considering shear lag effects.

DIRECT DESIGN TABLES

Admissible load values (with no increases) in kN/m².

loads conditioned by ULS

loads conditioned by SLS

2 SUPPORTS		SPAN [m]															
Thickness [mm]		1,00	1,10	1,20	1,30	1,40	1,50	1,60	1,70	1,80	1,90	2,00	2,10	2,20	2,30	2,40	2,50
0,50	(D)	2,10	1,57	1,20	0,93	0,74	0,59	0,48	0,39	0,32	0,27	0,22	-	-	-	-	-
	(A)	2,15	1,61	1,24	0,98	0,78	0,64	0,52	0,44	0,37	0,31	0,27	-	-	-	-	-
0,60	(D)	2,56	1,91	1,46	1,14	0,90	0,72	0,58	0,48	0,39	0,33	0,27	-	-	-	-	-
	(A)	2,62	1,97	1,51	1,19	0,95	0,78	0,64	0,53	0,45	0,38	0,33	-	-	-	-	-
0,70	(D)	3,02	2,25	1,72	1,34	1,06	0,85	0,69	0,56	0,47	0,39	0,32	-	-	-	-	-
	(A)	3,08	2,32	1,78	1,40	1,12	0,91	0,75	0,63	0,53	0,45	0,39	-	-	-	-	-
0,75	(D)	3,25	2,42	1,85	1,44	1,14	0,92	0,74	0,61	0,50	0,42	0,35	-	-	-	-	-
	(A)	3,32	2,49	1,92	1,51	1,21	0,98	0,81	0,68	0,57	0,48	0,41	-	-	-	-	-

3 SUPPORTS		SPAN [m]															
Thickness [mm]		1,00	1,10	1,20	1,30	1,40	1,50	1,60	1,70	1,80	1,90	2,00	2,10	2,20	2,30	2,40	2,50
0,50	(D)	4,20	3,54	2,99	2,34	1,86	1,51	1,23	1,02	0,85	0,72	0,61	0,52	0,45	-	-	-
	(A)	4,26	3,60	3,03	2,38	1,91	1,55	1,28	1,07	0,90	0,76	0,65	0,57	0,49	-	-	-
0,60	(D)	5,30	4,47	3,64	2,85	2,27	1,84	1,50	1,24	1,04	0,88	0,74	0,63	0,54	0,47	-	-
	(A)	5,33	4,51	3,69	2,90	2,33	1,89	1,56	1,30	1,09	0,93	0,80	0,69	0,60	0,52	-	-
0,70	(D)	6,42	5,29	4,29	3,36	2,68	2,17	1,77	1,47	1,23	1,03	0,88	0,75	0,64	0,55	0,48	-
	(A)	6,52	5,39	4,35	3,42	2,74	2,23	1,84	1,53	1,29	1,10	0,94	0,81	0,71	0,62	0,54	-
0,75	(D)	6,88	5,68	4,61	3,62	2,88	2,33	1,91	1,58	1,32	1,11	0,94	0,81	0,69	0,60	0,52	0,45
	(A)	6,99	5,79	4,68	3,68	2,95	2,40	1,98	1,65	1,39	1,18	1,01	0,87	0,76	0,67	0,59	0,52

4 SUPPORTS		SPAN [m]															
Thickness [mm]		1,00	1,10	1,20	1,30	1,40	1,50	1,60	1,70	1,80	1,90	2,00	2,10	2,20	2,30	2,40	2,50
0,50	(D)	4,09	3,06	2,35	1,83	1,46	1,18	0,96	0,80	0,66	0,56	0,47	0,40	0,34	-	-	-
	(A)	4,13	3,10	2,39	1,88	1,51	1,22	1,01	0,84	0,71	0,60	0,52	0,45	0,39	-	-	-
0,60	(D)	4,98	3,73	2,86	2,24	1,78	1,44	1,17	0,97	0,81	0,68	0,57	0,49	0,42	0,36	-	-
	(A)	5,03	3,78	2,91	2,29	1,83	1,49	1,23	1,02	0,86	0,73	0,63	0,54	0,47	0,41	-	-
0,70	(D)	5,87	4,39	3,37	2,64	2,10	1,69	1,38	1,14	0,95	0,80	0,68	0,58	0,49	0,42	0,37	-
	(A)	5,93	4,46	3,43	2,70	2,16	1,76	1,45	1,21	1,02	0,86	0,74	0,64	0,56	0,49	0,43	-
0,75	(D)	6,31	4,73	3,62	2,84	2,26	1,82	1,49	1,23	1,03	0,86	0,73	0,62	0,53	0,46	0,39	0,34
	(A)	6,38	4,79	3,69	2,90	2,33	1,89	1,56	1,30	1,09	0,93	0,80	0,69	0,60	0,52	0,46	0,41

SIDE 1 - ROOF



SIDE 2 - FACADE

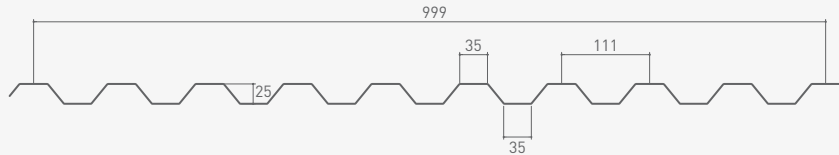

Nominal Thickness [mm]	Design Thickness [mm]	Weight		Resistance Moment [kN.m/m]	Inertia Moment [cm ⁴ /m]	Web Crushing Resistance [kN/m]	Shear Resistance [kN/m]
		kg/m ²	kg/ml				
0,50	0,46	4,91	4,91	0,96	5,13	16,79	36,22
0,60	0,56	5,89	5,90	1,27	6,60	24,07	46,77
0,70	0,66	6,88	6,89	1,61	8,14	32,44	55,13
0,75	0,71	7,37	7,38	1,78	8,93	37,03	59,30

Note: All the values for resistant moment and inertia moment presented in this table were calculated without considering shear lag effects.

Radius = 4mm



SLS - limit deflection: L/200 descending loads



SLS - limit deflection: L/150 ascending loads

DIRECT DESIGN TABLES

Admissible load values (with no increases) in kN/m².

loads conditioned by ULS

loads conditioned by SLS

2 SUPPORTS		SPAN [m]															
Thickness [mm]		1,00	1,10	1,20	1,30	1,40	1,50	1,60	1,70	1,80	1,90	2,00	2,10	2,20	2,30	2,40	2,50
0,50	(D)	4,09	3,06	2,35	1,83	1,46	1,18	0,96	0,79	0,66	0,55	0,47	0,40	0,34	0,29	0,25	0,22
	(A)	5,16	4,14	3,19	2,51	2,01	1,63	1,35	1,12	0,95	0,80	0,69	0,60	0,52	0,45	0,40	0,35
0,60	(D)	5,26	3,94	3,02	2,36	1,88	1,52	1,24	1,03	0,85	0,72	0,61	0,52	0,44	0,38	0,33	0,28
	(A)	6,83	5,33	4,11	3,23	2,59	2,10	1,73	1,44	1,22	1,03	0,89	0,77	0,67	0,58	0,51	0,45
0,70	(D)	6,49	4,86	3,73	2,92	2,32	1,88	1,53	1,27	1,06	0,89	0,75	0,64	0,55	0,47	0,41	0,35
	(A)	8,62	6,57	5,06	3,98	3,19	2,59	2,14	1,78	1,50	1,28	1,09	0,94	0,82	0,72	0,63	0,56
0,75	(D)	7,13	5,34	4,09	3,20	2,55	2,06	1,69	1,39	1,16	0,98	0,83	0,71	0,60	0,52	0,45	0,39
	(A)	9,56	7,21	5,55	4,37	3,50	2,84	2,34	1,95	1,65	1,40	1,20	1,04	0,90	0,79	0,69	0,61

3 SUPPORTS		SPAN [m]															
Thickness [mm]		1,00	1,10	1,20	1,30	1,40	1,50	1,60	1,70	1,80	1,90	2,00	2,10	2,20	2,30	2,40	2,50
0,50	(D)	4,01	3,44	2,95	2,57	2,26	2,01	1,78	1,61	1,44	1,32	1,20	1,04	0,90	0,78	0,68	0,60
	(A)	5,16	4,27	3,59	3,07	2,65	2,31	2,04	1,81	1,61	1,45	1,31	1,19	1,09	1,00	0,92	0,85
0,60	(D)	5,45	4,67	4,01	3,49	3,07	2,72	2,41	2,18	1,96	1,77	1,56	1,34	1,16	1,01	0,88	0,77
	(A)	6,83	5,65	4,75	4,05	3,50	3,05	2,69	2,39	2,13	1,92	1,74	1,58	1,44	1,32	1,22	1,11
0,70	(D)	7,07	6,04	5,18	4,51	3,97	3,49	3,12	2,79	2,51	2,27	1,93	1,66	1,44	1,25	1,09	0,96
	(A)	8,62	7,13	6,00	5,12	4,42	3,86	3,40	3,01	2,69	2,42	2,19	1,99	1,82	1,67	1,53	1,37
0,75	(D)	7,93	6,70	5,82	5,06	4,40	3,91	3,50	3,13	2,81	2,49	2,12	1,82	1,58	1,37	1,20	1,05
	(A)	9,56	7,91	6,65	5,68	4,90	4,28	3,76	3,34	2,98	2,68	2,43	2,20	2,01	1,85	1,69	1,50

4 SUPPORTS		SPAN [m]															
Thickness [mm]		1,00	1,10	1,20	1,30	1,40	1,50	1,60	1,70	1,80	1,90	2,00	2,10	2,20	2,30	2,40	2,50
0,50	(D)	4,84	4,15	3,57	3,15	2,77	2,31	1,89	1,57	1,32	1,11	0,95	0,81	0,70	0,61	0,53	0,46
	(A)	6,44	5,33	4,48	3,82	3,30	2,88	2,54	2,16	1,82	1,55	1,33	1,15	1,00	0,87	0,77	0,68
0,60	(D)	6,57	5,63	4,90	4,27	3,67	2,97	2,44	2,03	1,70	1,43	1,22	1,05	0,90	0,78	0,68	0,60
	(A)	8,52	7,05	5,93	5,06	4,37	3,81	3,33	2,78	2,34	1,99	1,71	1,47	1,28	1,12	0,99	0,87
0,70	(D)	8,53	7,30	6,27	5,46	4,53	3,67	3,01	2,50	2,10	1,77	1,51	1,29	1,12	0,97	0,85	0,74
	(A)	10,77	8,90	7,49	6,39	5,51	4,81	4,11	3,42	2,88	2,45	2,10	1,82	1,58	1,38	1,22	1,08
0,75	(D)	9,57	8,20	7,04	6,13	4,97	4,03	3,31	2,75	2,30	1,95	1,66	1,42	1,23	1,07	0,93	0,81
	(A)	11,94	9,87	8,30	7,08	6,11	5,33	4,51	3,76	3,17	2,69	2,31	1,99	1,73	1,52	1,34	1,18

SIDE 1 - ROOF



SIDE 2 - FACADE

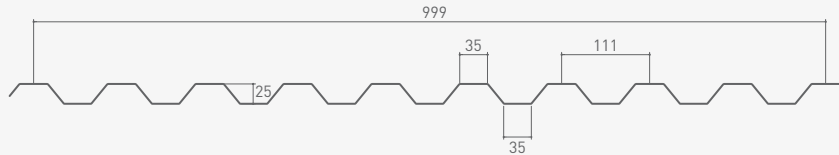

Nominal Thickness [mm]	Design Thickness [mm]	Weight		Resistance Moment [kN.m/m]	Inertia Moment [cm ⁴ /m]	Web Crushing Resistance [kN/m]	Shear Resistance [kN/m]
		kg/m ²	kg/ml				
0,50	0,46	4,91	4,91	0,96	5,13	16,79	36,22
0,60	0,56	5,89	5,90	1,27	6,60	24,07	46,77
0,70	0,66	6,88	6,89	1,61	8,14	32,44	55,13
0,75	0,71	7,37	7,38	1,78	8,93	37,03	59,30

Note: All the values for resistant moment and inertia moment presented in this table were calculated without considering shear lag effects.

Radius = 4mm



SLS - limit deflection: L/200 descending loads



SLS - limit deflection: L/150 ascending loads

DIRECT DESIGN TABLES

Admissible load values (with no increases) in kN/m².

loads conditioned by ULS

loads conditioned by SLS

2 SUPPORTS		SPAN [m]															
Thickness [mm]		1,00	1,10	1,20	1,30	1,40	1,50	1,60	1,70	1,80	1,90	2,00	2,10	2,20	2,30	2,40	2,50
0,50	(D)	4,01	3,00	2,30	1,80	1,43	1,15	0,94	0,78	0,65	0,54	0,46	0,39	0,33	0,29	0,25	0,21
	(A)	5,41	4,07	3,13	2,46	1,97	1,60	1,32	1,10	0,93	0,79	0,68	0,58	0,51	0,44	0,39	0,35
0,60	(D)	5,17	3,87	2,96	2,32	1,85	1,49	1,22	1,01	0,84	0,70	0,60	0,51	0,43	0,37	0,32	0,28
	(A)	6,96	5,23	4,03	3,17	2,54	2,06	1,70	1,42	1,19	1,02	0,87	0,75	0,65	0,57	0,50	0,45
0,70	(D)	6,38	4,77	3,66	2,86	2,28	1,84	1,51	1,24	1,04	0,87	0,74	0,63	0,54	0,46	0,40	0,34
	(A)	8,59	6,45	4,97	3,91	3,13	2,55	2,10	1,75	1,47	1,25	1,07	0,93	0,81	0,71	0,62	0,55
0,75	(D)	7,00	5,24	4,02	3,15	2,50	2,02	1,65	1,37	1,14	0,96	0,81	0,69	0,59	0,51	0,44	0,38
	(A)	9,43	7,08	5,46	4,29	3,44	2,79	2,30	1,92	1,62	1,37	1,18	1,02	0,89	0,77	0,68	0,60

3 SUPPORTS		SPAN [m]															
Thickness [mm]		1,00	1,10	1,20	1,30	1,40	1,50	1,60	1,70	1,80	1,90	2,00	2,10	2,20	2,30	2,40	2,50
0,50	(D)	4,41	3,73	3,25	2,83	2,49	2,21	1,98	1,77	1,59	1,40	1,19	1,02	0,88	0,77	0,67	0,59
	(A)	5,73	4,74	3,99	3,40	2,94	2,56	2,26	2,00	1,79	1,61	1,46	1,32	1,21	1,09	0,95	0,84
0,60	(D)	5,99	5,13	4,40	3,83	3,37	3,00	2,69	2,40	2,13	1,80	1,53	1,32	1,14	0,99	0,86	0,76
	(A)	7,58	6,27	5,27	4,50	3,88	3,39	2,98	2,65	2,37	2,13	1,92	1,75	1,60	1,40	1,23	1,09
0,70	(D)	7,76	6,64	5,70	4,96	4,37	3,88	3,44	3,07	2,63	2,22	1,90	1,63	1,41	1,22	1,07	0,94
	(A)	9,57	7,92	6,66	5,68	4,91	4,28	3,77	3,34	2,99	2,68	2,43	2,21	1,97	1,72	1,52	1,34
0,75	(D)	8,72	7,37	6,40	5,57	4,90	4,31	3,86	3,44	2,88	2,44	2,08	1,79	1,55	1,34	1,18	1,03
	(A)	10,62	8,79	7,39	6,30	5,44	4,75	4,18	3,71	3,31	2,98	2,69	2,45	2,16	1,89	1,66	1,47

4 SUPPORTS		SPAN [m]															
Thickness [mm]		1,00	1,10	1,20	1,30	1,40	1,50	1,60	1,70	1,80	1,90	2,00	2,10	2,20	2,30	2,40	2,50
0,50	(D)	5,31	4,56	3,92	3,42	2,80	2,26	1,86	1,54	1,29	1,09	0,93	0,79	0,68	0,59	0,52	0,45
	(A)	7,16	5,92	4,98	4,25	3,67	3,08	2,26	2,12	1,78	1,52	1,30	1,12	0,98	0,86	0,75	0,67
0,60	(D)	7,21	6,19	5,39	4,51	3,60	2,92	2,39	1,99	1,66	1,41	1,20	1,03	0,89	0,77	0,67	0,59
	(A)	9,46	7,83	6,58	5,61	4,85	3,97	3,27	2,73	2,30	1,95	1,67	1,45	1,26	1,10	0,97	0,86
0,70	(D)	9,36	8,02	6,89	5,57	4,45	3,60	2,96	2,45	2,06	1,74	1,48	1,27	1,10	0,95	0,83	0,73
	(A)	11,96	9,89	8,32	7,09	6,02	4,89	4,03	3,36	2,83	2,41	2,06	1,78	1,55	1,36	1,19	1,06
0,75	(D)	10,52	9,01	7,80	6,12	4,88	3,96	3,25	2,70	2,26	1,91	1,63	1,40	1,20	1,05	0,91	0,80
	(A)	13,26	10,21	9,22	7,87	6,61	5,37	4,43	3,69	3,11	2,64	2,27	1,96	1,70	1,49	1,31	1,16

SIDE 1 - ROOF

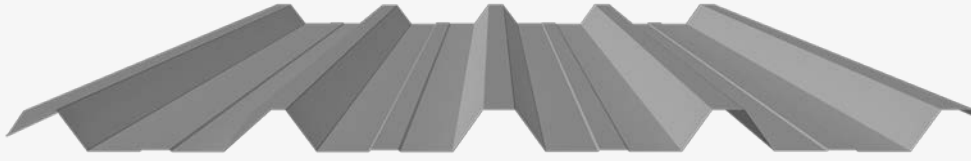

SIDE 2 - FACADE

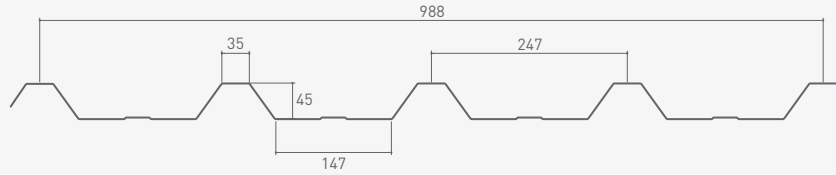

Nominal Thickness [mm]	Design Thickness [mm]	Weight		Superior Flange in Compression		Inferior Flange in Compression		Web Crushing Resistance [kN/m]	Shear Resistance [kN/m]
		kg/m ²	kg/ml	Resistance Moment [kN.m/m]	Inertia Moment [cm ⁴ /m]	Resistance Moment [kN.m/m]	Inertia Moment [cm ⁴ /m]		
0,50	0,46	4,97	5,03	0,90	12,87	1,12	12,79	7,67	15,70
0,60	0,56	5,96	6,03	1,30	17,75	1,52	16,49	10,99	25,23
0,70	0,66	6,95	7,03	1,76	22,93	1,83	20,34	14,82	35,04
0,75	0,71	7,45	7,54	2,01	25,14	1,99	22,31	16,91	40,55

Radius = 4mm



SLS - limit deflection: L/200 descending loads



SLS - limit deflection: L/150 ascending loads

Note: All the values for resistant moment and inertia moment presented in this table were calculated without considering shear lag effects.

DIRECT DESIGN TABLES

Admissible load values (with no increases) in kN/m².

loads conditioned by ULS

loads conditioned by SLS

2 SUPPORTS		SPAN [m]																				
Thickness [mm]		1,00	1,10	1,20	1,30	1,40	1,50	1,60	1,70	1,80	1,90	2,00	2,10	2,20	2,30	2,40	2,50	2,60	2,70	2,80	2,90	3,00
0,50	(D)	4,76	3,93	3,29	2,80	2,41	2,09	1,83	1,62	1,44	1,29	1,16	1,04	0,92	0,80	0,70	0,61	0,54	0,48	0,42	0,38	0,34
	(A)	5,93	4,90	4,11	3,50	3,01	2,62	2,30	2,03	1,72	1,45	1,24	1,06	0,92	0,80	0,70	0,61	0,54	0,48	0,42	0,37	0,33
0,60	(D)	6,88	5,67	4,76	4,05	3,48	3,02	2,65	2,34	2,08	1,86	1,68	1,48	1,28	1,12	0,98	0,86	0,75	0,67	0,59	0,53	0,47
	(A)	8,05	6,64	5,57	4,74	4,08	3,55	3,11	2,65	2,22	1,88	1,60	1,38	1,19	1,03	0,90	0,79	0,70	0,62	0,55	0,49	0,43
0,70	(D)	9,32	7,69	6,45	5,49	4,72	4,11	3,60	3,18	2,83	2,54	2,24	1,92	1,66	1,45	1,27	1,11	0,98	0,87	0,77	0,69	0,62
	(A)	9,69	8,00	6,71	5,71	4,91	4,27	3,75	3,27	2,74	2,32	1,98	1,70	1,47	1,28	1,12	0,98	0,86	0,76	0,68	0,60	0,54
0,75	(D)	10,67	8,81	7,39	6,28	5,41	4,70	4,12	3,65	3,24	2,87	2,45	2,11	1,83	1,59	1,39	1,22	1,08	0,96	0,85	0,76	0,68
	(A)	10,52	8,68	7,28	6,20	5,33	4,64	4,07	3,58	3,01	2,55	2,18	1,87	1,62	1,41	1,23	1,08	0,95	0,84	0,75	0,66	0,59

3 SUPPORTS		SPAN [m]																				
Thickness [mm]		1,00	1,10	1,20	1,30	1,40	1,50	1,60	1,70	1,80	1,90	2,00	2,10	2,20	2,30	2,40	2,50	2,60	2,70	2,80	2,90	3,00
0,50	(D)	2,79	2,46	2,17	1,93	1,73	1,57	1,41	1,30	1,18	1,09	1,01	0,93	0,86	0,81	0,76	0,71	0,66	0,62	0,58	0,55	0,51
	(A)	2,76	2,43	2,14	1,93	1,73	1,55	1,41	1,29	1,18	1,08	1,01	0,93	0,86	0,80	0,75	0,70	0,66	0,61	0,57	0,53	0,49
0,60	(D)	3,97	3,51	3,09	2,75	2,47	2,23	2,04	1,84	1,69	1,56	1,42	1,32	1,22	1,13	1,05	0,98	0,92	0,86	0,81	0,76	0,71
	(A)	3,99	3,52	3,09	2,75	2,47	2,24	2,02	1,85	1,69	1,55	1,43	1,32	1,22	1,13	1,06	0,98	0,92	0,86	0,80	0,76	0,71
0,70	(D)	5,28	4,55	4,02	3,55	3,16	2,83	2,56	2,34	2,14	1,95	1,80	1,65	1,52	1,43	1,32	1,23	1,15	1,08	1,01	0,95	0,90
	(A)	5,22	4,54	4,00	3,57	3,17	2,83	2,56	2,32	2,12	1,95	1,80	1,65	1,54	1,42	1,31	1,24	1,15	1,08	1,01	0,95	0,89
0,75	(D)	5,85	5,10	4,43	3,96	3,52	3,16	2,86	2,60	2,35	2,17	1,98	1,84	1,69	1,57	1,45	1,35	1,26	1,18	1,11	1,04	0,99
	(A)	5,87	5,11	4,43	3,96	3,52	3,15	2,85	2,59	2,37	2,15	1,99	1,82	1,70	1,57	1,45	1,35	1,26	1,19	1,12	1,05	0,99

4 SUPPORTS		SPAN [m]																				
Thickness [mm]		1,00	1,10	1,20	1,30	1,40	1,50	1,60	1,70	1,80	1,90	2,00	2,10	2,20	2,30	2,40	2,50	2,60	2,70	2,80	2,90	3,00
0,50	(D)	3,29	2,92	2,58	2,30	2,07	1,88	1,69	1,56	1,42	1,32	1,21	1,12	1,05	0,98	0,92	0,86	0,80	0,75	0,71	0,67	0,63
	(A)	3,28	2,90	2,56	2,28	2,05	1,86	1,70	1,54	1,43	1,31	1,21	1,12	1,04	0,97	0,91	0,85	0,80	0,75	0,71	0,67	0,62
0,60	(D)	4,79	4,17	3,67	3,27	2,95	2,67	2,44	2,24	2,03	1,87	1,71	1,60	1,47	1,37	1,29	1,20	1,12	1,05	0,99	0,93	0,87
	(A)	4,74	4,12	3,70	3,30	2,97	2,66	2,43	2,21	2,04	1,87	1,73	1,58	1,47	1,38	1,27	1,20	1,12	1,05	0,99	0,93	0,88
0,70	(D)	6,26	5,41	4,80	4,23	3,78	3,45	3,08	2,81	2,58	2,35	2,18	2,00	1,87	1,73	1,61	1,50	1,40	1,31	1,23	1,16	1,10
	(A)	6,19	5,40	4,77	4,26	3,79	3,40	3,12	2,80	2,56	2,36	2,18	2,00	1,86	1,72	1,62	1,50	1,40	1,31	1,23	1,16	1,10
0,75	(D)	6,94	6,07	5,38	4,74	4,22	3,80	3,44	3,14	2,84	2,62	2,42	2,23	2,05	1,90	1,79	1,67	1,55	1,46	1,37	1,29	1,21
	(A)	6,95	6,06	5,37	4,72	4,20	3,77	3,41	3,11	2,85	2,63	2,40	2,23	2,05	1,90	1,79	1,66	1,55	1,45	1,36	1,28	1,21

SIDE 1 - ROOF

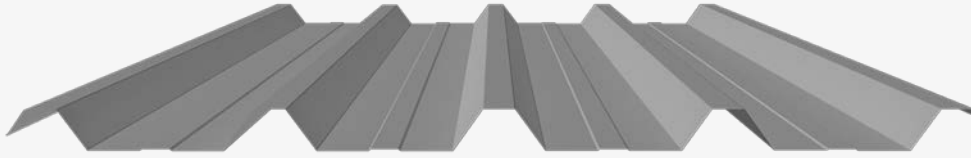

SIDE 2 - FACADE

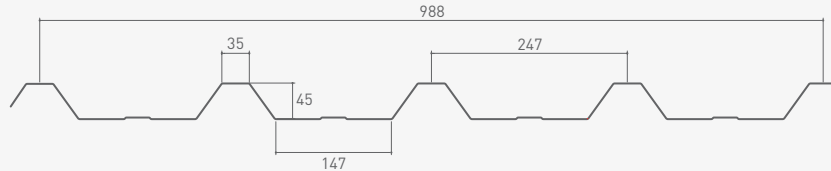

Nominal Thickness [mm]	Design Thickness [mm]	Weight		Superior Flange in Compression		Inferior Flange in Compression		Web Crushing Resistance [kN/m]	Shear Resistance [kN/m]
		kg/m ²	kg/ml	Resistance Moment [kN.m/m]	Inertia Moment [cm ⁴ /m]	Resistance Moment [kN.m/m]	Inertia Moment [cm ⁴ /m]		
0,50	0,46	4,97	5,03	0,90	12,87	1,12	12,79	7,67	15,70
0,60	0,56	5,96	6,03	1,30	17,75	1,52	16,49	10,99	25,23
0,70	0,66	6,95	7,03	1,76	22,93	1,83	20,34	14,82	35,04
0,75	0,71	7,45	7,54	2,01	25,14	1,99	22,31	16,91	40,55

Radius = 4mm



SLS - limit deflection: L/200 descending loads



SLS - limit deflection: L/150 ascending loads

Note: All the values for resistant moment and inertia moment presented in this table were calculated without considering shear lag effects.

DIRECT DESIGN TABLES

Admissible load values (with no increases) in kN/m².

loads conditioned by ULS

loads conditioned by SLS

2 SUPPORTS		SPAN [m]																				
Thickness [mm]		1,00	1,10	1,20	1,30	1,40	1,50	1,60	1,70	1,80	1,90	2,00	2,10	2,20	2,30	2,40	2,50	2,60	2,70	2,80	2,90	3,00
0,50	(D)	5,14	4,24	3,55	3,02	2,60	2,26	1,98	1,75	1,55	1,39	1,19	1,02	0,88	0,77	0,67	0,59	0,52	0,46	0,40	0,36	0,32
	(A)	6,35	5,24	4,40	3,74	3,22	2,80	2,42	2,01	1,68	1,43	1,22	1,04	0,90	0,78	0,68	0,60	0,53	0,46	0,41	0,37	0,33
0,60	(D)	7,43	6,13	5,14	4,37	3,76	3,27	2,87	2,53	2,25	1,94	1,65	1,42	1,23	1,07	0,93	0,82	0,72	0,64	0,57	0,50	0,45
	(A)	9,12	7,53	6,32	5,37	4,63	3,80	3,12	2,60	2,18	1,84	1,57	1,35	1,17	1,01	0,89	0,78	0,68	0,60	0,54	0,48	0,42
0,70	(D)	10,08	8,32	6,98	5,94	5,11	4,44	3,90	3,44	3,00	2,54	2,17	1,86	1,61	1,40	1,23	1,08	0,95	0,84	0,75	0,67	0,59
	(A)	10,98	9,06	7,60	6,47	5,57	4,70	3,86	3,21	2,69	2,28	1,94	1,67	1,44	1,26	1,10	0,96	0,85	0,75	0,67	0,59	0,53
0,75	(D)	11,53	9,52	7,99	6,80	5,85	5,09	4,46	3,94	3,33	2,82	2,41	2,07	1,79	1,56	1,37	1,20	1,06	0,94	0,83	0,74	0,66
	(A)	11,92	9,84	8,26	7,03	6,05	5,16	4,24	3,52	2,95	2,50	2,14	1,84	1,59	1,38	1,21	1,06	0,93	0,82	0,73	0,65	0,58

3 SUPPORTS		SPAN [m]																				
Thickness [mm]		1,00	1,10	1,20	1,30	1,40	1,50	1,60	1,70	1,80	1,90	2,00	2,10	2,20	2,30	2,40	2,50	2,60	2,70	2,80	2,90	3,00
0,50	(D)	3,00	2,61	2,33	2,08	1,87	1,66	1,52	1,40	1,27	1,18	1,08	1,00	0,93	0,86	0,82	0,76	0,71	0,66	0,62	0,59	0,55
	(A)	2,98	2,63	2,31	2,05	1,84	1,67	1,52	1,38	1,27	1,17	1,07	0,99	0,92	0,86	0,80	0,75	0,71	0,66	0,61	0,57	0,53
0,60	(D)	4,31	3,75	3,36	3,00	2,69	2,40	2,20	2,02	1,84	1,71	1,57	1,45	1,34	1,25	1,18	1,10	1,02	0,96	0,90	0,85	0,80
	(A)	4,31	3,74	3,34	2,97	2,67	2,42	2,18	2,00	1,82	1,69	1,56	1,44	1,34	1,25	1,17	1,10	1,02	0,96	0,90	0,83	0,78
0,70	(D)	5,65	4,99	4,39	3,90	3,53	3,17	2,87	2,58	2,37	2,18	2,00	1,83	1,71	1,58	1,47	1,37	1,28	1,20	1,12	1,06	1,00
	(A)	5,64	4,99	4,40	3,92	3,53	3,15	2,84	2,58	2,36	2,17	2,00	1,83	1,71	1,57	1,48	1,37	1,29	1,21	1,13	1,06	1,00
0,75	(D)	6,37	5,60	4,95	4,36	3,88	3,49	3,16	2,88	2,64	2,40	2,22	2,04	1,88	1,74	1,64	1,52	1,42	1,33	1,25	1,18	1,10
	(A)	6,34	5,62	4,95	4,35	3,92	3,51	3,17	2,88	2,63	2,39	2,21	2,05	1,89	1,74	1,63	1,52	1,42	1,32	1,24	1,17	1,11

4 SUPPORTS		SPAN [m]																				
Thickness [mm]		1,00	1,10	1,20	1,30	1,40	1,50	1,60	1,70	1,80	1,90	2,00	2,10	2,20	2,30	2,40	2,50	2,60	2,70	2,80	2,90	3,00
0,50	(D)	3,55	3,15	2,78	2,48	2,23	2,02	1,82	1,67	1,53	1,42	1,31	1,21	1,14	1,06	0,99	0,93	0,86	0,81	0,76	0,72	0,66
	(A)	3,54	3,08	2,76	2,46	2,22	2,01	1,81	1,67	1,52	1,40	1,31	1,21	1,12	1,05	0,98	0,92	0,86	0,81	0,76	0,72	0,67
0,60	(D)	5,10	4,45	4,00	3,57	3,22	2,92	2,63	2,42	2,21	2,05	1,89	1,75	1,65	1,53	1,43	1,33	1,24	1,17	1,10	1,02	0,92
	(A)	5,11	4,45	3,99	3,56	3,21	2,87	2,63	2,42	2,21	2,03	1,89	1,75	1,63	1,52	1,43	1,33	1,25	1,17	1,08	0,97	0,87
0,70	(D)	6,81	5,92	5,22	4,65	4,22	3,80	3,44	3,10	2,85	2,63	2,41	2,24	2,07	1,92	1,78	1,68	1,57	1,47	1,39	1,31	1,21
	(A)	6,68	5,93	5,24	4,68	4,16	3,79	3,42	3,11	2,85	2,62	2,42	2,22	2,07	1,91	1,79	1,67	1,57	1,47	1,34	1,20	1,08
0,75	(D)	7,68	6,65	5,90	5,21	4,65	4,18	3,79	3,46	3,18	2,89	2,68	2,46	2,30	2,13	1,98	1,85	1,73	1,62	1,52	1,43	1,34
	(A)	7,65	6,67	5,90	5,19	4,69	4,21	3,80	3,46	3,17	2,92	2,67	2,48	2,28	2,14	1,98	1,85	1,72	1,63	1,48	1,32	1,19

C PURLINS

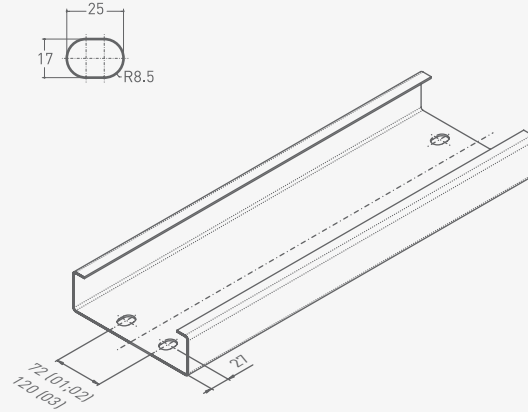
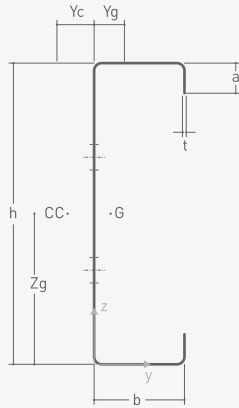

Note: C purlin can be profiled in any height between 140 and 300 mm and the flange width varies from 60 to 75 mm.

GEOMETRIC PROPERTIES

Cold formed sections for cladding support of roofs and/or façades.

	G kg/m	h mm	b mm	a mm	t mm	Área mm ²	y _g mm	z _g mm	I _{y_g} mm ⁴	I _{z_g} mm ⁴	W _{y_g} mm ³	W _{z_g} mm ³	i _{y_g} mm	i _{z_g} mm	I _w mm ⁴	I _w mm ⁴	y _c mm
C140x60x1,5	3,5	140	60	20	1,5	441	19,3	69,25	1380840	233601	19940	5959	56	23	1013638507	331	29,3
C140x60x1,8	4,2	140	60	20	1,8	527	19,2	69,10	1642329	276048	23767	7071	56	23	1189999614	569	29,1
C140x60x2,0	4,7	140	60	20	2,0	584	19,1	69,00	1813987	303584	26290	7798	56	23	1302974988	779	28,9
C170x60x1,5	3,9	170	60	20	1,5	486	17,5	84,25	2167141	248821	25723	6071	67	23	1507653427	365	27,7
C170x60x1,8	4,7	170	60	20	1,8	581	17,4	84,10	2579978	294047	30677	7204	67	22	1772293964	628	27,5
C170x60x2,0	5,2	170	60	20	2,0	644	17,3	84,00	2851447	323388	33946	7944	67	22	1942256894	859	27,4
C170x60x2,5	6,5	170	60	20	2,5	800	17,1	83,75	3517077	393960	41995	9744	66	22	2345161114	1667	27,1
C200x65x1,8	5,2	200	65	20	1,8	653	17,7	99,10	3955874	373924	39918	8212	78	24	3011421479	705	28,5
C200x65x2,0	5,8	200	65	20	2,0	724	17,6	99,00	4374733	411508	44189	9059	78	24	3304402438	965	28,4
C200x65x2,5	7,3	200	65	20	2,5	900	17,4	98,75	5404082	502151	54725	11125	77	24	4002637887	1875	28,1
C240x65x1,8	5,8	240	65	20	1,8	725	15,9	119,10	6081975	394177	51066	8335	92	23	4477152721	783	26,8
C240x65x2,0	6,4	240	65	20	2,0	804	15,8	119,00	6729080	433792	56547	9196	91	23	4915608680	1072	26,7
C240x65x2,5	8,0	240	65	20	2,5	1000	15,6	118,75	8322103	529329	70081	11292	91	23	5963032071	2083	26,4
C250x70x1,8	6,1	250	70	20	1,8	761	17,2	124,1	6979100	476440	56238	9335	96	25	5819610899	822	28,7
C250x70x2,0	6,8	250	70	20	2,0	844	17,1	124,0	7723193	524624	62284	10303	96	25	6393869625	1125	28,6
C250x70x2,5	8,4	250	70	20	2,5	1050	16,9	123,8	9556348	641094	77223	12664	95	25	7769573353	2188	28,3
C270x75x1,8	6,5	270	75	20	1,8	815	18,0	134,10	8701439	574912	64888	10417	103	27	8108097013	880	30,3
C270x75x2,0	7,2	270	75	20	2,0	904	17,9	134,00	9631693	633373	71878	11501	103	26	8914400830	1205	30,1
C270x75x2,5	9,0	270	75	20	2,5	1125	17,7	133,75	11925723	774964	89164	14147	103	26	10851514686	2344	29,8
C300x80x2,0	7,9	300	80	20	2,0	984	18,4	149,00	12818680	762554	86031	12792	114	28	13130887167	1312	31,3
C300x80x2,5	9,8	300	80	20	2,5	1225	18,2	148,75	15883665	934061	106781	15749	114	28	16012098206	2552	31,0
C300x80x3,0	11,8	300	80	20	3,0	1464	18,0	148,50	18893523	1098248	127229	18611	114	27	18741632744	4392	30,7

Note: The geometric properties presented here refer to the rectified gross section, from the cold formed section, in accordance with the standard EN1993-1-3.

Z PURLINS

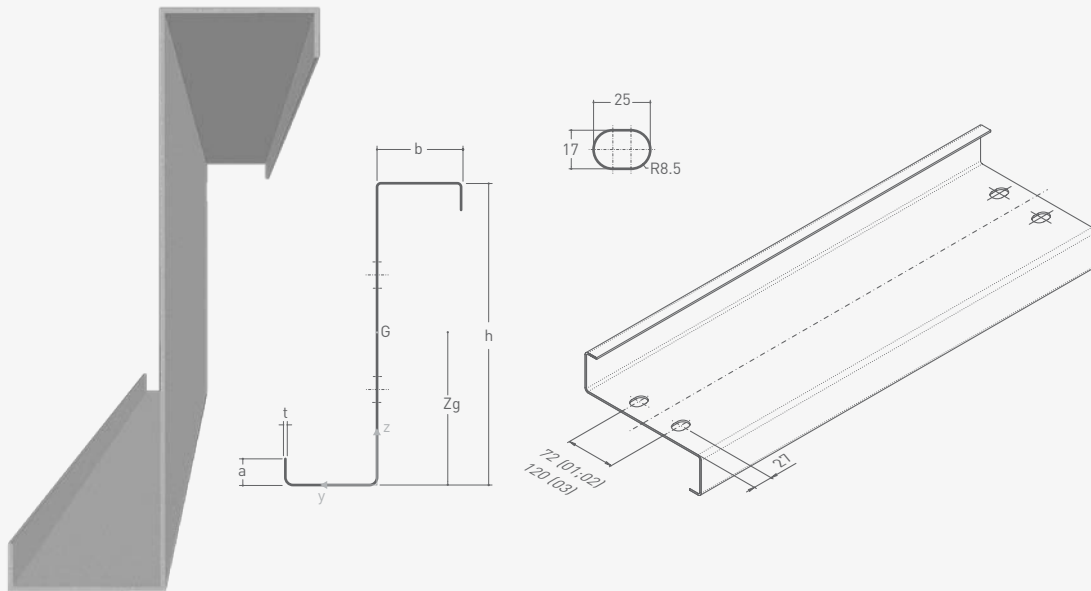

Note: The geometric properties presented here refer to the rectified gross section, from the cold formed section, in accordance with the standard EN1993-1-3.

GEOMETRIC PROPERTIES

Cold formed sections for cladding support of roofs and/or façades.

	G kg/m	h mm	b mm	a mm	t mm	Área mm ²	y _s mm	z _s mm	I _{y_s} mm ⁴	I _{z_s} mm ⁴	W _y mm ³	W _z mm ³	i _y mm	i _z mm	I _w mm ⁴	I _t mm ⁴
Z140x60x1,5	3,5	140	60	20	1,5	441	0,0	69,25	1380840	397886	19940	6801	56	30	1318559266	331
Z140x60x1,8	4,2	140	60	20	1,8	527	0,0	69,10	1642329	469557	23767	8068	56	30	1549406762	569
Z140x60x2,0	4,7	140	60	20	2,0	584	0,0	69,00	1813987	515931	26290	8895	56	30	1697547433	779
Z170x60x1,5	3,9	170	60	20	1,5	486	0,0	84,25	2167141	397895	25723	6802	67	29	2012536373	365
Z170x60x1,8	4,7	170	60	20	1,8	581	0,0	84,10	2579978	469572	30677	8068	67	28	2367230003	628
Z170x60x2,0	5,2	170	60	20	2,0	644	0,0	84,00	2851447	515951	33946	8896	67	28	2595285249	859
Z170x60x2,5	6,5	170	60	20	2,5	800	0,0	83,75	3517077	627077	41995	10906	66	28	3136757370	1667
Z200x65x1,8	5,2	200	65	20	1,8	653	0,0	99,10	3955874	577682	39918	9141	78	30	4076420335	705
Z200x65x2,0	5,8	200	65	20	2,0	724	0,0	99,00	4374733	635197	44189	10082	78	30	4474174788	965
Z200x65x2,5	7,3	200	65	20	2,5	900	0,0	98,75	5404082	773418	54725	12375	77	29	5423043503	1875
Z240x65x1,8	5,8	240	65	20	1,8	725	0,0	119,10	6081975	577701	51066	9141	92	28	6087933601	783
Z240x65x2,0	6,4	240	65	20	2,0	804	0,0	119,00	6729080	635224	56547	10083	91	28	6684716334	1072
Z240x65x2,5	8,0	240	65	20	2,5	1000	0,0	118,75	8322103	773470	70081	12376	91	28	8110764126	2083
Z270x75x1,8	6,5	270	75	20	1,8	815	0,0	134,10	8701439	839249	64888	11465	103	32	11089325070	880
Z270x75x2,0	7,2	270	75	20	2,0	904	0,0	134,00	9631693	923897	71878	12656	103	32	12192754114	1205
Z270x75x2,5	9,0	270	75	20	2,5	1125	0,0	133,75	11925723	1128301	89164	15044	103	32	14844115326	2344
Z300x80x2,0	7,9	300	80	20	2,0	984	0,0	149,00	12818680	1095344	86031	14043	114	33	17977289667	1312
Z300x80x2,5	9,8	300	80	20	2,5	1225	0,0	148,75	15883665	1339329	106781	17282	114	33	21922001034	2552
Z300x80x3,0	11,8	300	80	20	3,0	1464	0,0	148,50	18893523	1571937	127229	20415	114	33	25658737015	4392

Note: The geometric properties presented here refer to the rectified gross section, from the cold formed section, in accordance with the standard EN1993-1-3.

CONSTRUCTION DETAILS

FAÇADE – DOUBLE SHEETING

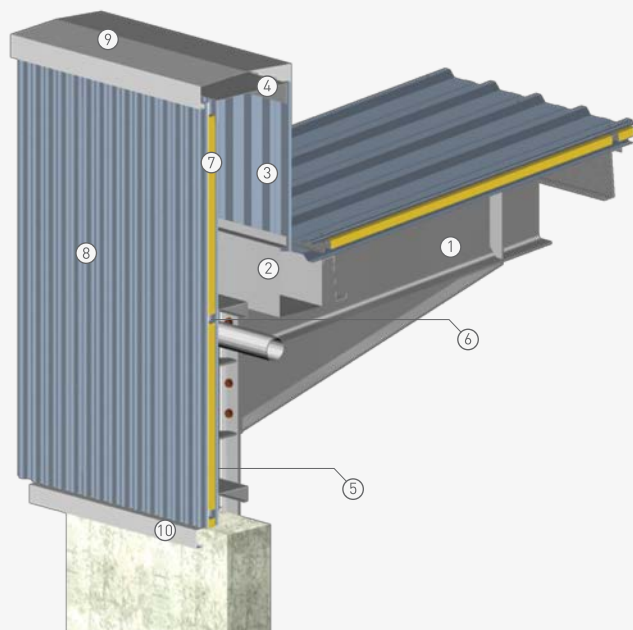

- ① Main structure
- ② Single gutter
- ③ P4-76-20 sheeting (side 1)
- ④ C purlin
- ⑤ P4-76-20 sheeting (side 1)
- ⑥ Omega A12-A
- ⑦ Thermal and acoustic insulation
- ⑧ Perfil P4-76-20 (face1)
- ⑨ A-03B helmet
- ⑩ A-11A baseboard

FAÇADE – SINGLE SHEETING

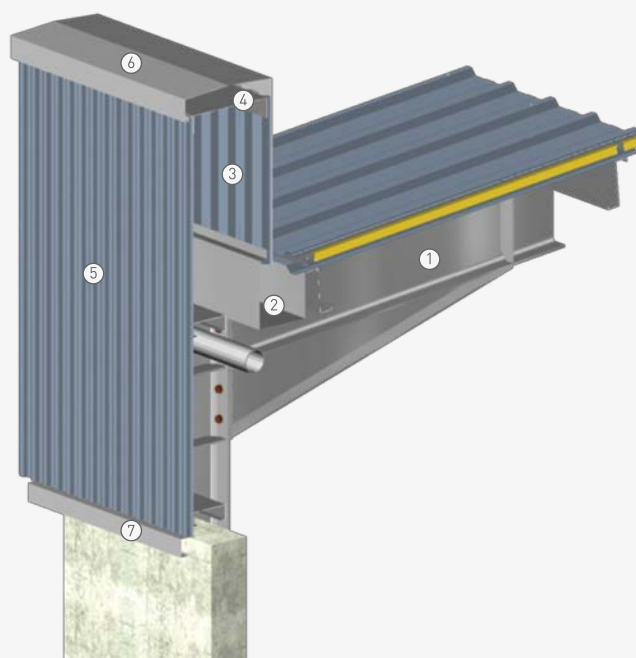

- ① Main structure
- ② Single gutter
- ③ P4-76-20 sheeting (face1)
- ④ C purlin
- ⑤ P4-76-20 sheeting (face1)
- ⑥ A-03B helmet
- ⑦ A-11A baseboard

CONSTRUCTION DETAILS

ROOF - DOUBLE SHEETING

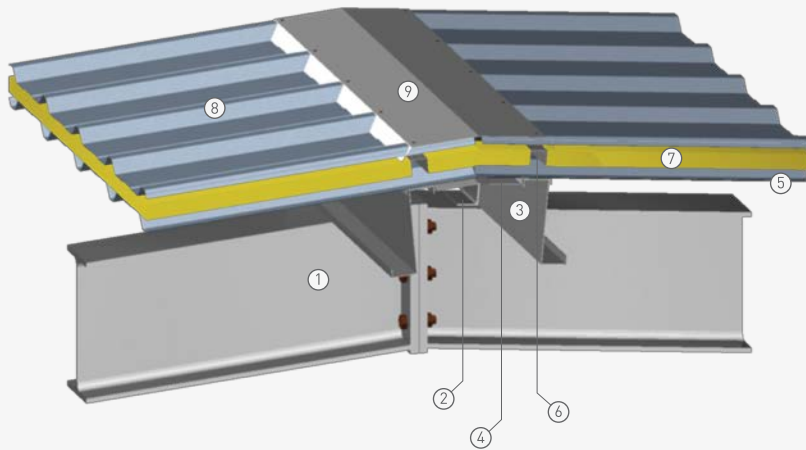

- ① Main structure
- ② Link
- ③ Z purlins
- ④ Pre-top A-02A
- ⑤ P1-272-30 sheeting (side 1)
- ⑥ Omega A-12A
- ⑦ Thermal and acoustic insulation
- ⑧ P1-272-30 sheeting (side 1)
- ⑨ Bent top A-01A

ROOF - SINGLE SHEETING

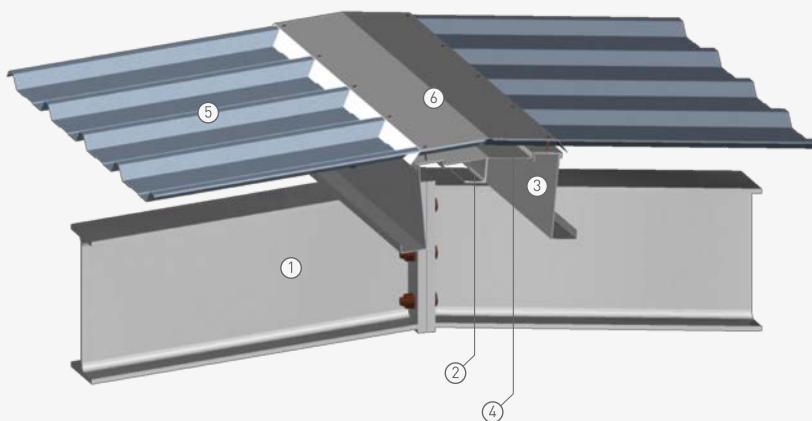

- ① Main structure
- ② Link
- ③ Z purlins
- ④ Pre-Top A-02A
- ⑤ P1-272-30 sheeting (face 1)
- ⑥ Bent top A-01A

CONSTRUCTION DETAILS

DECK SYSTEM – BITUMINOUS MEMBRANE

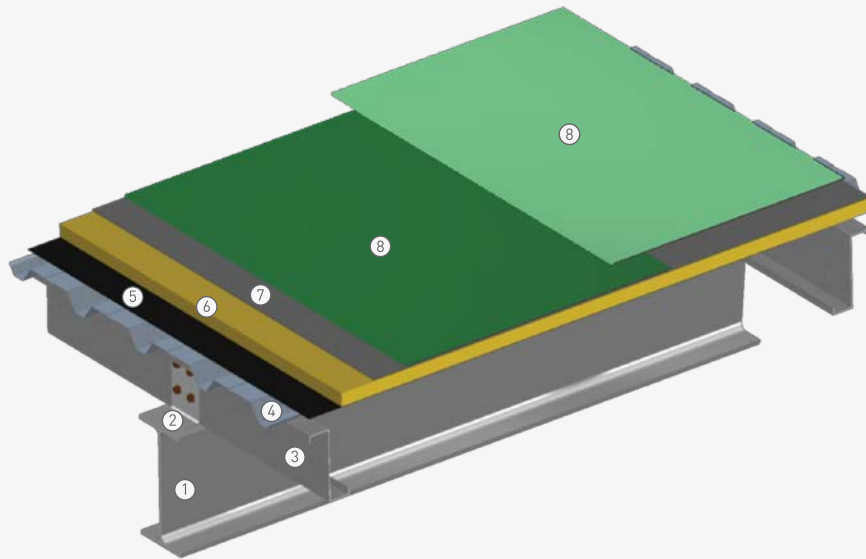

- ① Main structure
- ② Link
- ③ Z purlins
- ④ P2-247-45 sheeting (side 1)
- ⑤ Steam stopper barrier
- ⑥ Thermal and acoustic insulation
- ⑦ Waterproofing bituminous membrane (layer 1)
- ⑧ Waterproofing bituminous membrane (layer 2)

DECK SYSTEM – PVC MEMBRANE

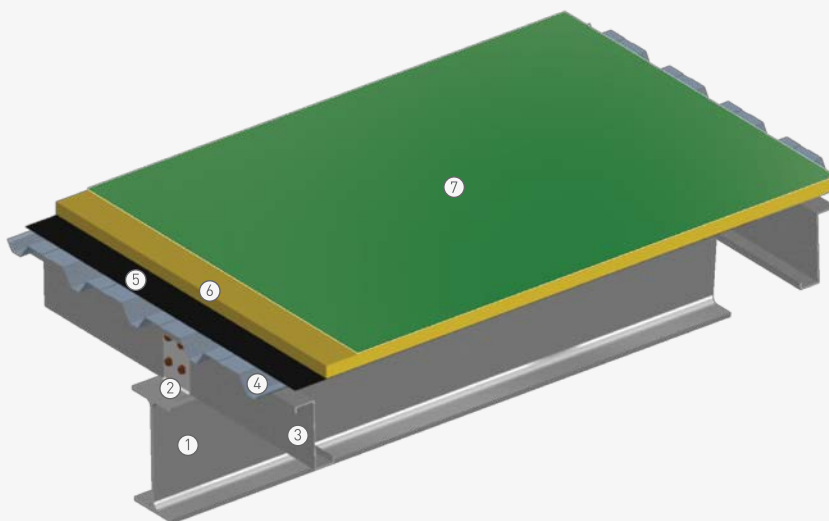

- ① Main structure
- ② Link
- ③ Z purlins
- ④ P2-247-45 sheeting (face 1)
- ⑤ Steam stopper barrier
- ⑥ Thermal and acoustic insulation
- ⑦ PVC waterproofing membrane

ACCESSORIES

All the accessories are manufactured by cutting and bending the sheeting; its dimensions can be adapted according to the specificities of the project, except for the joint coverings. Maximum development of each unit 1250 mm. Maximum length 6000 mm, except for the gutters.

PRE-TOP

A-02A

α - variable angle X - variable size

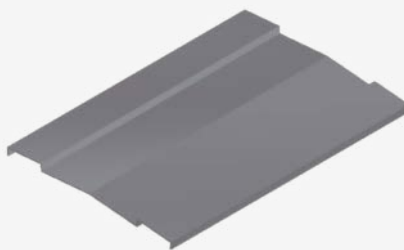
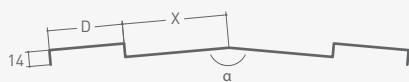

PRE-TOP	
Purlin	D [mm]
C140 / Z140	65
C170 / Z170	65
C200 / Z200	70
C240 / Z240	70
C250	75
C270 / Z270	80
C300 / Z300	85

HELMET

A-03A

A-03B

* indicative measurements X - variable size

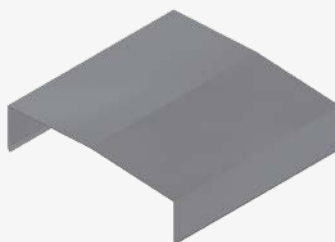
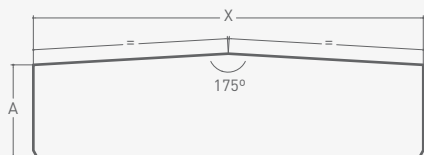

Profile	*A [mm]	B [mm]
P0-272-30		
P1-272-30	80	35
P2-272-30		
P4-76-20	80	25
P5-111-25	80	30
P6-274-45	110	50

A-03B

* indicative measurements X - variable size

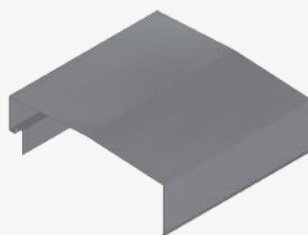
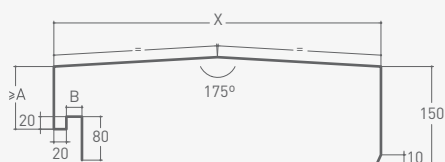

Profile	*A [mm]	B [mm]
P0-272-30		
P1-272-30	80	35
P2-272-30		
P4-76-20	80	25
P5-111-25	80	30
P6-274-45	110	50

A-03C

* indicative measurements X - variable size

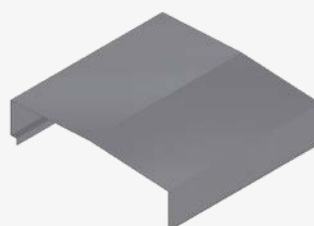
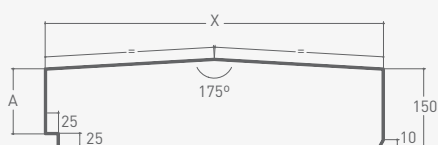

Profile	*A [mm]	B [mm]
P0-272-30		
P1-272-30	80	35
P2-272-30		
P4-76-20	80	25
P5-111-25	80	30
P6-274-45	110	50

ACCESSORIES

All the accessories are manufactured by cutting and bending the sheeting; its dimensions can be adapted according to the specificities of the project, except for the joint coverings. Maximum development of each unit 1250 mm. Maximum length 6000 mm, except for the gutters.

GUTTER

maximum length 14200 mm

SINGLE GUTTER

X - variable size

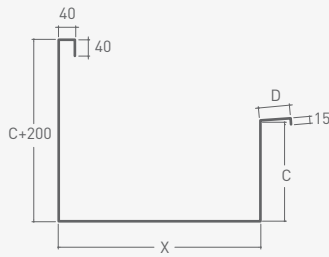

Purlin	C [mm]	D [mm]
C140 / Z140	140	65
C170 / Z170	170	65
C200 / Z200	200	70
C240 / Z240	240	70
C250	250	75
C270 / Z270	270	80
C300 / Z300	300	85

DOUBLE GUTTER

X - variable size

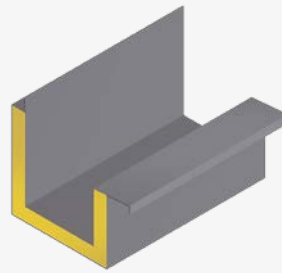
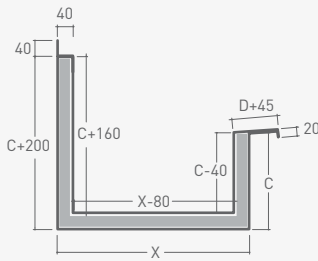

Purlin	C [mm]	D [mm]
C140 / Z140	140	65
C170 / Z170	170	65
C200 / Z200	200	70
C240 / Z240	240	70
C250	250	75
C270 / Z270	270	80
C300 / Z300	300	85

GABLE

A-05A

X - variable size

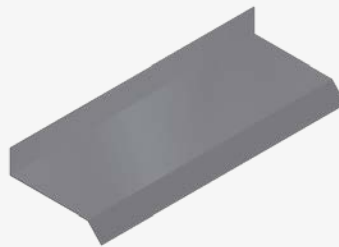
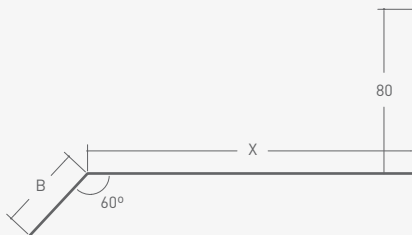

Profile	B [mm]
P0-272-30	35
P1-272-30	
P2-272-30	
P5-111-25	30
P6-274-45	50

A-05B

X - variable size

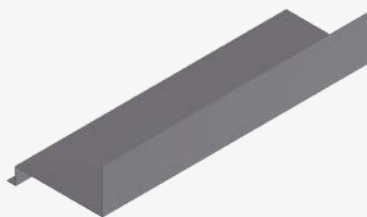
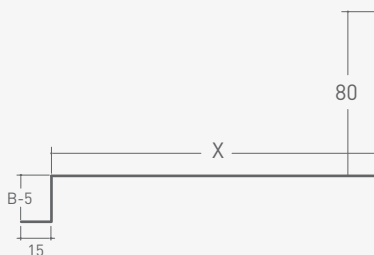

Perfil	B [mm]
P0-272-30	35
P1-272-30	
P2-272-30	
P5-111-25	30
P6-274-45	50

ACCESSORIES

All the accessories are manufactured by cutting and bending the sheeting; its dimensions can be adapted according to the specificities of the project, except for the joint coverings. Maximum development of each unit 1250 mm. Maximum length 6000 mm, except for the gutters.

LINTEL

A-06A

* indicative measurements X - variable size

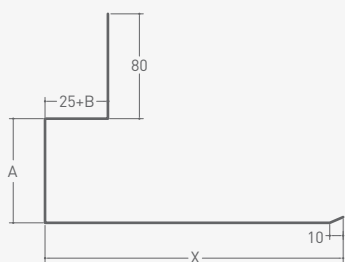

Profile	*A [mm]	B [mm]
P0-272-30		
P1-272-30	80	35
P2-272-30		
P4-76-20	80	25
P5-111-25	80	30
P6-274-45	110	50

SILL

A-07A

* indicative measurements X - variable size

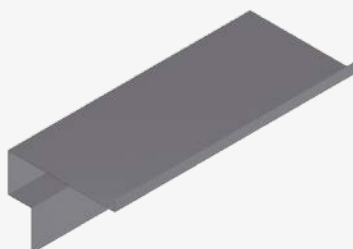
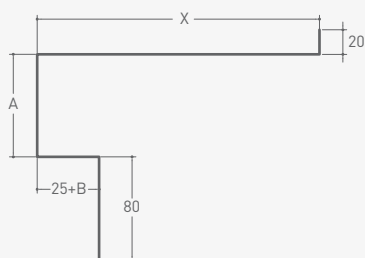

Profile	*A [mm]	B [mm]
P0-272-30		
P1-272-30	80	35
P2-272-30		
P4-76-20	80	25
P5-111-25	80	30
P6-274-45	110	50

A-07B

* indicative measurements X - variable size

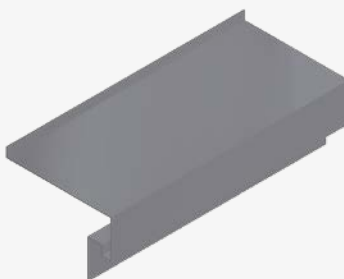

Profile	*A [mm]	B [mm]
P0-272-30		
P1-272-30	80	35
P2-272-30		
P4-76-20	80	25
P5-111-25	80	30
P6-274-45	110	50

FRAME

A-08A

* indicative measurements X - variable size

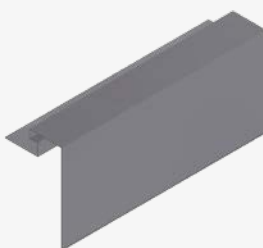
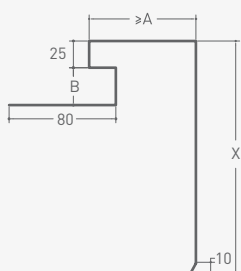

Profile	*A [mm]	B [mm]
P0-272-30		
P1-272-30	80	35
P2-272-30		
P4-76-20	80	25
P5-111-25	80	30
P6-274-45	110	50

A-08B

* indicative measurements X - variable size

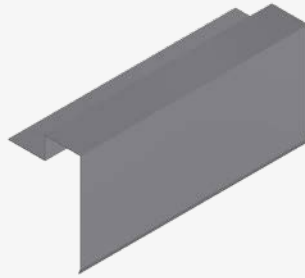
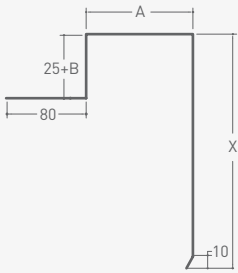

Perfil	*A [mm]	B [mm]
P0-272-30	80	35
P1-272-30		
P2-272-30		
P4-76-20	80	25
P5-111-25	80	30
P6-274-45	110	50

POSITIVE CORNERS

A-09A

* indicative measurements

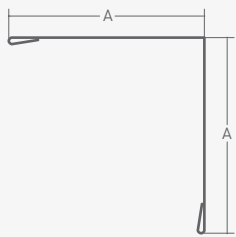

Profile	*A [mm]	B [mm]
P0-272-30	80	35
P1-272-30		
P2-272-30		
P4-76-20	80	25
P5-111-25	80	30
P6-274-45	110	50

A-09B

* indicative measurements

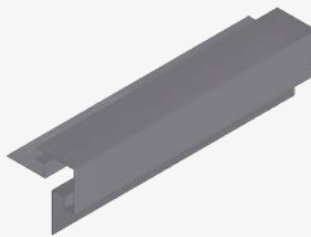
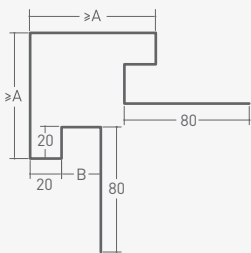

Profile	*A [mm]	B [mm]
P0-272-30	80	35
P1-272-30		
P2-272-30		
P4-76-20	80	25
P5-111-25	80	30
P6-274-45	110	50

A-09C

* indicative measurements

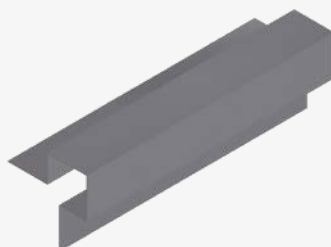
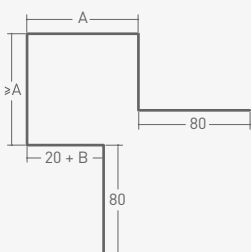

Profile	*A [mm]	B [mm]
P0-272-30	80	35
P1-272-30		
P2-272-30		
P4-76-20	80	25
P5-111-25	80	30
P6-274-45	110	50

NEGATIVE CORNER A-10A

* indicative measurements

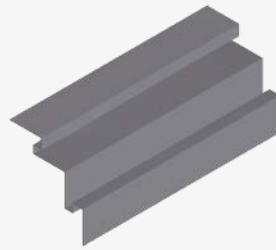
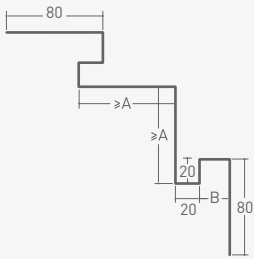

Profile	*A [mm]	B [mm]
P0-272-30		
P1-272-30	80	35
P2-272-30		
P4-76-20	80	25
P5-111-25	80	30
P6-274-45	110	50

BASEBOARD

A-11A

* indicative measurements X - variable size

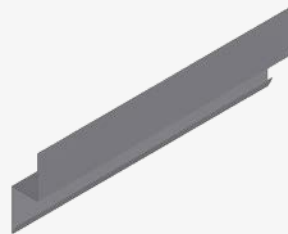
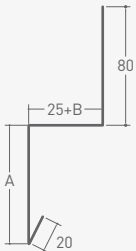

Profile	*A [mm]	B [mm]
P0-272-30		
P1-272-30	80	35
P2-272-30		
P4-76-20	80	25
P5-111-25	80	30
P6-274-45	110	50

A-11B

* indicative measurements X - variable size

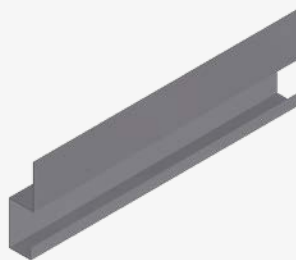
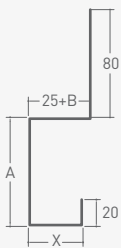

Profile	*A [mm]	B [mm]
P0-272-30		
P1-272-30	80	35
P2-272-30		
P4-76-20	80	25
P5-111-25	80	30
P6-274-45	110	50

OMEGA

A-12A

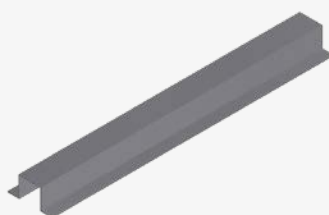
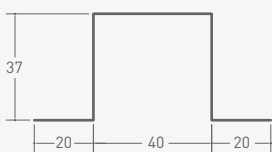

JOINT COVERINGS

A-13A

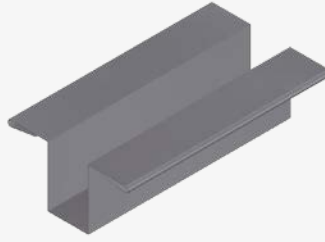
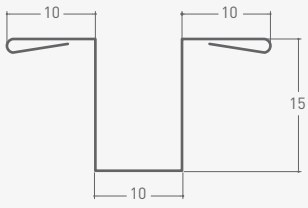

PROPS FOR FENCES

A-14A

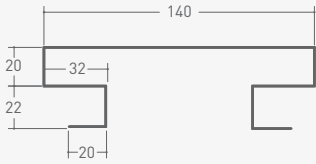

P4-76-20

A-14B

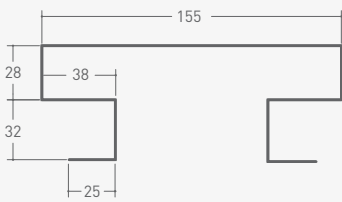

P0-272-30
P1-272-30
P2-272-30

AVAILABLE COLORS

The colors shown in this catalog comply to our standards with the greatest possible precision. However, some disparities are inevitable; that is why we always recommend a color test with a real sample.

RAL 9010
PURE WHITE

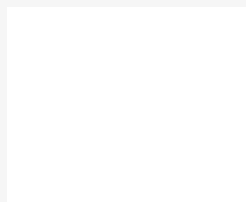

RAL 1015
LIGHT IVORY

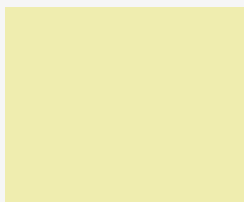

RAL 9006
WHITE ALUMINIUM

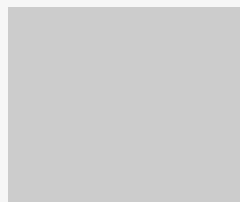

RAL 9007
GREY ALUMINIUM



RAL 7022
UMBRA GREY

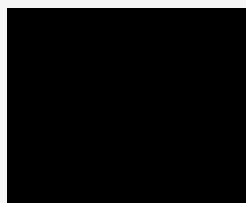

RAL 7016
ANTRACITE GREY



RAL 9005
JET BLACK

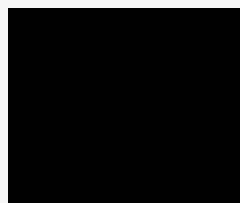

RAL 3000
FLAME RED



RAL 8004
COPPER BROWN



RAL 3009
OXIDE RED

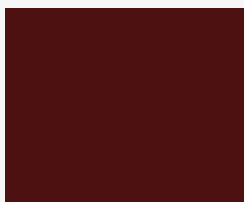

RAL 3005
WINE RED



RAL 6005
MOSS GREEN

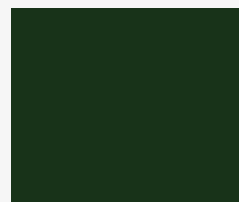

RAL 6009
FIR GREEN

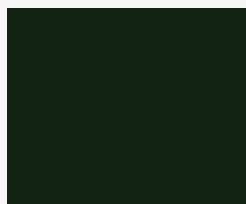

RAL 5005
SIGNAL BLUE



RAL 5010
GENTIANE BLUE



RAL 5002
ULTRAMARINE BLUE





PORTUGAL

AV. DE SÃO LOURENÇO, N.º 41
APARTADO 2100
4705-444 CELEIRÓS BRAGA, PORTUGAL

T +351 253 305 600
F +351 253 672 756
INFO@OFELIZ.COM
OFELIZ.COM

ANGOLA

E.N. LUANDA-CATETE KM 47
LUANDA, ANGOLA

T +244 933 686 816
INFO@OFELIZANGOLA.COM
OFELIZANGOLA.COM

MOZAMBIQUE

AV. DE MAGUIGUANA, N.º 599, 1.º ANDAR
MAPUTO, MOÇAMBIQUE

T +258 840 526 945
INFO@OFELIZMOZAMBIQUE.COM
OFELIZMOZAMBIQUE.COM

